

TECHNICAL MANUAL
OPERATOR, UNIT, AND DIRECT SUPPORT
MAINTENANCE MANUAL

TANK, 3, 000 GALLON FABRIC,
COLLAPSIBLE, POTABLE WATER,
SEMI-TRAILER MOUNTED

NSN: 5430-01-181-4071
MODEL NO. 3, 000 GALLON

NSN: 5430-01-372-6901
MODEL NO. 91093

EIC: ZFX

DISTRIBUTION STATEMENT A: Approved for public release; distribution is unlimited.

HEADQUARTERS, DEPARTMENT OF THE ARMY
27 OCTOBER 1986

CHANGE
NO. 5

HEADQUARTERS
DEPARTMENT OF THE ARMY
WASHINGTON, D.C., 27 December 1996

Operator, Unit and Direct Support
Maintenance Manual

TANK, 3000 GALLON FABRIC, COLLAPSIBLE,
POTABLE WATER, SEMI-TRAILER MOUNTED
NSN: 5430-01-181-4071
Model No. 3, 000 Gallon
NSN: 5430-01-372-6901
Model No. 91093
EIC: ZFX

DISTRIBUTION STATEMENT A: Approved for public release; distribution is unlimited

TM 5-5430-213-13&P, 27 October 1986, is changed as follows:

1. Title is changed as indicated above.
2. Remove and insert pages as indicated below. New or changed text material is indicated by a vertical bar in the margin. An illustration change is indicated by a miniature pointing hand.

Remove pages	Insert pages
i through iv	i through iv
3-3 and 3-4	3-3 and 3-4
-----	3-6.1 through 3-6.3/(3-6.4 blank)
3-7 and 3-8	3-7 and 3-8
C-1 through C-6	C-1 through C-6
-----	E-1/(E-2 blank)
Cover	Cover

3. Retain this sheet in front of manual for reference purposes.

By Order of the Secretary of the Army:

DENNIS J. REIMER
General, *United States Army*
Chief of Staff

Official:



JOEL B. HUDSON

*Administrative Assistant to the
Secretary of the Army*

03126

DISTRIBUTION:

To be distributed in accordance with DA Form 12-25-E, block
no. 3825, requirements for TM 5-5430-213-13&P.

CHANGE
NO. 4

HEADQUARTERS
DEPARTMENT OF THE ARMY
WASHINGTON, D.C., 30 SEPTEMBER 1993

Operator and Organizational Maintenance Manual

SEMI-TRAILER MOUNTED TANK, POTABLE WATER (DRINKING WATER)
3,000 GALLON

NSN: 5430-01-181-4071
Model No. 3,000 gallon
NSN: 5430-01-372-6901
MODEL NO. 91093

DISTRIBUTION STATEMENT A: Approved for public release; distribution is unlimited.

TM 5-5430-213-13&P, 27 October 1986, is changed as follows:

- Title is changed as indicated above.
- Remove and insert pages as indicated below. New or changed text material is indicated by a vertical bar in the margin. An illustration change is indicated by a miniature pointing hand.

Remove pages	Insert pages
i through iv	i through iv
1-1 through 1-4	1-1 through 1-5/(1-6 blank)
2-3 and 2-4	2-3 and 2-4
2-13 and 2-14	2-13 and 2-14
3-1 and 3-2	3-1 and 3-2
3-7 and 3-8	3-7 and 3-8
----	3-8.1 and 3-8.2
3-9 through 3-12	3-9 through 3-12
C-1 through C-6	C-1 through C-11/(C-12 blank)

- Retain this sheet in front of manual for reference purposes.

By Order of the Secretary of the Army:

GORDON R. SULLIVAN
General, United States Army
Chief of Staff

Official:

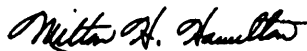

MILTON H. HAMILTON
Administrative Assistant to the
Secretary of the Army

05615

DISTRIBUTION:

To be distributed in accordance with DA Form 12-25-E, block no. 3825, requirements for TM 5-5430-213-13&P.

CHANGE

NO. 3

HEADQUARTERS
DEPARTMENT OF THE ARMY
WASHINGTON, D. C., 26 February 1993

Operator and Organizational Maintenance Manual

TANK, 3,000 GALLON FABRIC, COLLAPSIBLE, POTABLE WATER,
SEMI-TRAILER MOUNTED, NSN: 5430-01-181-4071, DAAK01-85-C-B195

DISTRIBUTION STATEMENT A: Approved for public release; distribution is unlimited

TM 5-5430-213-13&P, 27 October 1986, is changed as follows:

1. Remove and insert pages as indicated below. New or changed text material is indicated by a vertical bar in the margin. An illustration change is indicated by a miniature pointing hand.

Remove pages

Insert pages

C-1 through C-4

C-1 through C-4

2. Retain this sheet in front of manual for reference purposes.

By Order of the Secretary of the Army:

GORDON R. SULLIVAN
General, United States Army
Chief of Staff

Official:

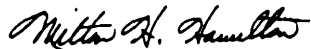

MILTON H. HAMILTON
Administrative Assistant to the
Secretary of the Army

03969

DISTRIBUTION:

To be distributed in accordance with DA Form 12-25-E, block no. 3825, requirements for TM 5-5430-213-13&P.

CHANGE
NO. 2

HEADQUARTERS
DEPARTMENT OF THE ARMY
WASHINGTON, D.C., 8 January 1990

Operator and Organizational Maintenance Manual

TANK, 3,000 GALLON FABRIC,
COLLAPSIBLE, POTABLE WATER,
SEMI-TRAILER MOUNTED

NSN: 5430-01-181-4071
DAAK01-85-C-B195

Approved for public release; distribution is unlimited

TM 5-5430-213-13&P, 27 October 1986, is changed as follows:

1. Remove and insert pages as indicated below. New or changed text material is indicated by a vertical bar in the margin. An illustration change is indicated by a miniature pointing hand.

Remove pages

Insert pages

2-13 and 2-14

2-13 and 2-14

2. Retain this sheet in front of manual for reference purposes.

By Order of the Secretary of the Army:

CARL E. VUONO
General United States Army,
Chief of Staff

Official:

WILLIAM J. MEEHAN, II
Brigadier General United States Army
The Adjutant General

DISTRIBUTION:

To be distributed in accordance with DA Form 12-25A, Operator and Unit Maintenance Requirements for Tank, Fabric, Collapsible, POL, 50,000, 10,000, 3,000 GAL.

CHANGE

HEADQUARTERS
DEPARTMENT OF THE ARMY
WASHINGTON, D. C. , 22 June 1988

No. 1

Operator and Organizational Maintenance Manual

TANK, 3,000 GALLON FABRIC,
COLLAPSIBLE, POTABLE WATER,
SEMI-TRAILER MOUNTED

NSN: 5430-01-181-4071
DAAK01-85-C-B195

TM 5-5430-213-13&P, 27 October 1986, is changed as follows:

1. Remove and insert pages as indicated below. New or changed text material is indicated by a vertical bar in the margin. An illustration change is indicated by a miniature pointing hand.

Remove pages

Insert pages

D-1 and D-2

2. Retain this sheet in front of manual for reference purposes.

By Order of the Secretary of the Army:

CARL E. VUONO
General, United States Army
Chief of Staff

Official:

R.L. DILWORTH
Brigadier General, United States Army
The Adjutant General

DISTRIBUTION:

To be distributed in accordance with DA Form 12-25A, Operator and Unit Maintenance requirements for Tank, Fabric, Collapsible, POL, 50,000, 10,000, 3,000 GAL.

W A R N I N G S

THIS TANK IS DESIGNED AND INTENDED FOR TRANSPORT OF DRINKABLE WATER ONLY. THE TRANSPORT - OR CONTACT WITH POL PRODUCTS WILL CONTAMINATE THE TANK AND WILL RESULT IN PERMANENT DAMAGE TO THE TANK MATERIAL AND POSSIBLE STRUCTURAL FAILURE.

BEFORE USING THIS EQUIPMENT, THE OPERATOR SHOULD BE THOROUGHLY FAMILIAR WITH OPERATING INSTRUCTIONS CONTAINED IN CHAPTER 2 OF THE OPERATION MANUAL. FAILURE TO COMPLY WITH THIS REQUIREMENT MAY DAMAGE THE EQUIPMENT AND JEOPARDIZE THE SAFETY OF OPERATING PERSONNEL.

THIS TANK CAN ONLY BE TRANSPORTED FULL OR EMPTY. A PARTIALLY FILLED TANK, BEING TRANSPORTED, WILL RESULT IN THE LOAD SHIFTING (SURGE) AND WILL RESULT IN THE REDUCTION OF VEHICLE CONTROL AND POSSIBLE RUPTURE OF THE TANK WALL. WHEN COMPLETELY EMPTY, THE TANK MAY BE ROLLED UP AND STORED.

TANK IS DESIGNED TO BE DRAINED BY GRAVITY OR SUCTION PUMP ONLY. USE OF AIR PRESSURE TO UNLOAD TANK IS NOT AUTHORIZED AS IT MAY CAUSE THE TANK TO BURST UNDER PRESSURE.

UNPACKING TANK -- REMOVE ALL PROTRUDING NAILS AND OTHER OBJECTS PRIOR TO ATTEMPTING TO REMOVE THE TANK FROM THE CONTAINER. THIS IS ESSENTIAL IN ORDER TO AVOID PUNCTURING THE TANK.

TESTING - - DO NOT AIR TEST THE TANK, OVER-PRESSURIZATION COULD CAUSE TANK TO BURST RESULTING IN DEATH OR SERIOUS INJURY TO PERSONNEL.

EQUIPMENT FAILURE - - IF EQUIPMENT FAILS TO OPERATE, REFER TO TROUBLE SHOOTING PROCEDURES IN CHAPTER 3.

**Operator, Unit and Direct Support
Maintenance Manual**

**TANK, 3000 GALLON FABRIC, COLLAPSIBLE,(
POTABLE WATER, SEMI-TRAILER MOUNTED**

NSN: 5430-01-181-4071

Model No. 3, 000 Gallon

NSN: 5430-01-372-6901C.

Model No. 91093

EIC: ZFX

REPORTING ERRORS AND RECOMMENDING IMPROVEMENTS

You can help improve this manual. If you find any mistakes, or if you know of a way to improve these procedures, please let us know. Mail your letter or DA Form 2028 (Recommended Changes to Publications and Blank Forms), or DA Form 2028-2 located in the back of this manual directly to: Commander, US Army Aviation and Troop Command, ATTN: AMSAT-I-MP, 4300 Goodfellow Blvd., St. Louis, MO 63120-1798. You may also submit your recommended changes by E-mail directly to <mpmt%avma28 @st-louisemh7.army.mil>. A reply will be furnished directly to you. Instructions for sending an electronic 2028 may be found at the back of this manual immediately preceding the hard copy 2028.

TABLE OF CONTENTS

CHAPTER 1	INTRODUCTION.....	Paragraph	Page
	Section I. General		
	Scope	1-1	1-1
	Maintenance Forms and Records	1-2	1-1
	Destruction of Army Material to Prevent Enemy Use.....	1-3	1-1
	Administrative Storage	1-4	1-1
	Section II. Description and Data		
	Description	1-5	1-1
	Warranty Data	1-5	1-1
	Tabulated Data.....	1-6	1-4
	Identification Plate (Model No. 3,000 gallon).....	1-7	1-4
	Identification Plate (Model 91093).....	1-7.1	1-5
	Information Plate (Model No. 3, 000 gallon).....	1-8	1-5
	Information Plate (Model 91093).....	1-8.1	1-5
CHAPTER 2	OPERATING INSTRUCTIONS		
	Section I. Service Upon Receipt of Material		
	General.....	2-1	2-1
	Uncrating the Equipment.....	2-2	2-1
	Installation	2-3	2-1
	Inspecting and Servicing the Equipment	2-4	2-3
	Correction of Deficiencies	2-5	2-8
	Section II. Controls and Instruments		
	General.....	2-6	2-8
	Filler/Discharge Valve	2-7	2-8
	Pressure Gage	2-8	2-8
	Pressure Gage Valve	2-9	2-8
	Hose Assembly	2-10	2-8
	Pressure Relief Valve.....	2-11	2-8

	Section III.	Operating Instructions Under Usual Conditions		
		Filling Tank.....	2-12	2-9
		Draining.....	2-13	2-12
		Repacking.....	2-14	2-13
	Section IV.	Movement to a New Worksite		
		General.....	2-15	2-14
	Section V.	Operating Under Unusual Conditions		
		General.....	2-16	2-14
		In Extreme Cold.....	2-17	2-14
		In Extreme Heat.....	2-18	2-14
		Operating in Dusty or Sandy Area.....	2-19	2-14
CHAPTER 3.	MAINTENANCE INSTRUCTIONS			
	Section I.	Introduction		
		General.....	3-1	3-1
	Section II.	Troubleshooting		
		General.....	3-2	3-2
	Section III.	Maintenance Procedures		
		General.....	3-3	3-3
		Visual Inspection Procedure.....	3-4	3-4
		Emergency Temporary Repairs (Exterior).....	3-5	3-4
		End Clamp Assembly.....	3-6	3-8
		Filler/Discharge Assembly.....	3-7	3-9
		Tie-Down Assembly.....	3-8	3-10
		Cleaning of Tank (Temporary and Long-Term.....	3-9	3-10
		Storage).....		
		Hydrostatic Testing Procedure.....	3-10	3-10
	Section IV.	Repair Kit		
		Repair Kit.....	3-5	3-5
				3-6
		Deleted		
APPENDIX A	REFERENCES			
		Destruction of Army Material.....	A-1	A-1
		Shipment and Storage.....	A-2	A-1
		Maintenance Forms Records.....	A-3	A-1
		Maintenance of Supplies and Equipment.....	A-4	A-1
APPENDIX B	MAINTENANCE ALLOCATION CHART			
	Section I.	General		
		General.....	B-1	B-1
		Explanation of Columns in Section II.....	B-2	B-1
	Section II.	Maintenance Allocation Chart.....		B-3
APPENDIX C	COMPONENT IDENTIFICATION LIST			
	Section I.	Introduction		
		Scope.....	C-1	C-1

TABLE OF CONTENTS (Continued)

APPENDIX D	Section II. Component Identification List.....	C-1
	ADDITIONAL AUTHORIZATION LIST	
	Section I. Introduction	
	Scope 1	D-1
	General..... 1	D-1
	Explanation of Listing 3	D-1
	Section II. Additional Authorization List.....	D-1
APPENDIX E	EXPENDABLE/DURABLE SUPPLIES AND MATERIALS LIST	
	Section I. Introduction	
	Scope E-1	E-1
	Explanation of Columns E-2	E-1

LIST OF ILLUSTRATIONS

<u>Figure</u>	<u>Title</u>	<u>Page</u>
1-1	3, 000 Gallon Potable Water Tank (Model 3, 000 gallon)	1-2
1-1A	3, 000 Gallon Potable Water Tank (Model 91093)	1-3
2-1	Crated Assembly	2-2
2-2, 2-3	Semi-Trailer Anchor Assembly.....	2-4
2-4	Tie Down Assembly (M-127 Trailer).....	2-5
2-5	Tie Down Assembly (M-871 Trailer).....	2-6
2-6	Tie Down Assembly (M-872 Trailer).....	2-7
2-7	Pressure Gage Assembly.....	2-10
2-8	Repacking Procedure.....	2-15
3-1	Installation of Sealing Clamp.....	3-5
3-2	Installation of Wood Plug	3-6
C-1	Tank With Hardware and Tie Down Assembly (Model 3, 000 gallon).....	C-7
C-1A	Tank With Hardware and Tie Down Assembly (Model 91093)	C-8
C-2	Filler/Discharge Assembly	C-9
C-3	Hose Assembly	C-10
C-4	Sealing Clamps and Wood Plugs.....	C-11

CHAPTER 1
INTRODUCTION

Section I. General

1-1. Scope

The scope of this manual covers the information and instructions necessary for the operation and maintenance of the 3,000 gallon capacity tank. This manual covers two models, one manufactured by Uniroyal and the other by Amfuel. The Uniroyal tank is hereafter referred to as Model No. 3,000 gallon and the Amfuel tank as Model 91093.

1-2. Maintenance Forms and Records

Maintenance forms and records that you are required to use are explained in DA PAM 738-750, the Army Maintenance Management System (TAMMS).

1-3. Destruction of Army Material to Prevent Enemy Use

The tanks may be destroyed by mechanical means, such as cutting the tank from end to end with a sharp instrument or by burning.

1-4. Maintenance of Supplies and Equipment

Maintenance of supplies and equipment is explained in TB-750-25, Maintenance of Supplies and Equipment, Army Test Measures and Diagnostic Equipment (TMDE Calibration and Repair Support Program).

Section II. Description and Data

1-5. Description

The tank is used for the storage and transport of potable water (drinking water). The assembled unit consists of a collapsible tank with pressure gage, end fittings, tie-down straps, emergency repair items, hose and tools to secure the tank safely on the M872, M871 and 127 semi-trailers. (See Fig. 1-1 and 1-1A, and Appendix C.)

Trailer tanks are warranted to be free of defects in workmanship and materials, and such tanks will be serviceable for a period of one year after the date of delivery when used in accordance with the manufacturer's instructions.

a. Collapsible Tank

Access to the tank interior is provided through the use of removable end clamps. When laid flat the tank is 28' long x 7' 4" wide x 4" high. When filled it assumes a pillow-like shape approximately 27' long x 5' 2" wide x 4' 6" high.

Handles are provided to facilitate positioning of the tank while empty. When not in use, the tank may be folded or rolled and stored in the sling and shipping container.

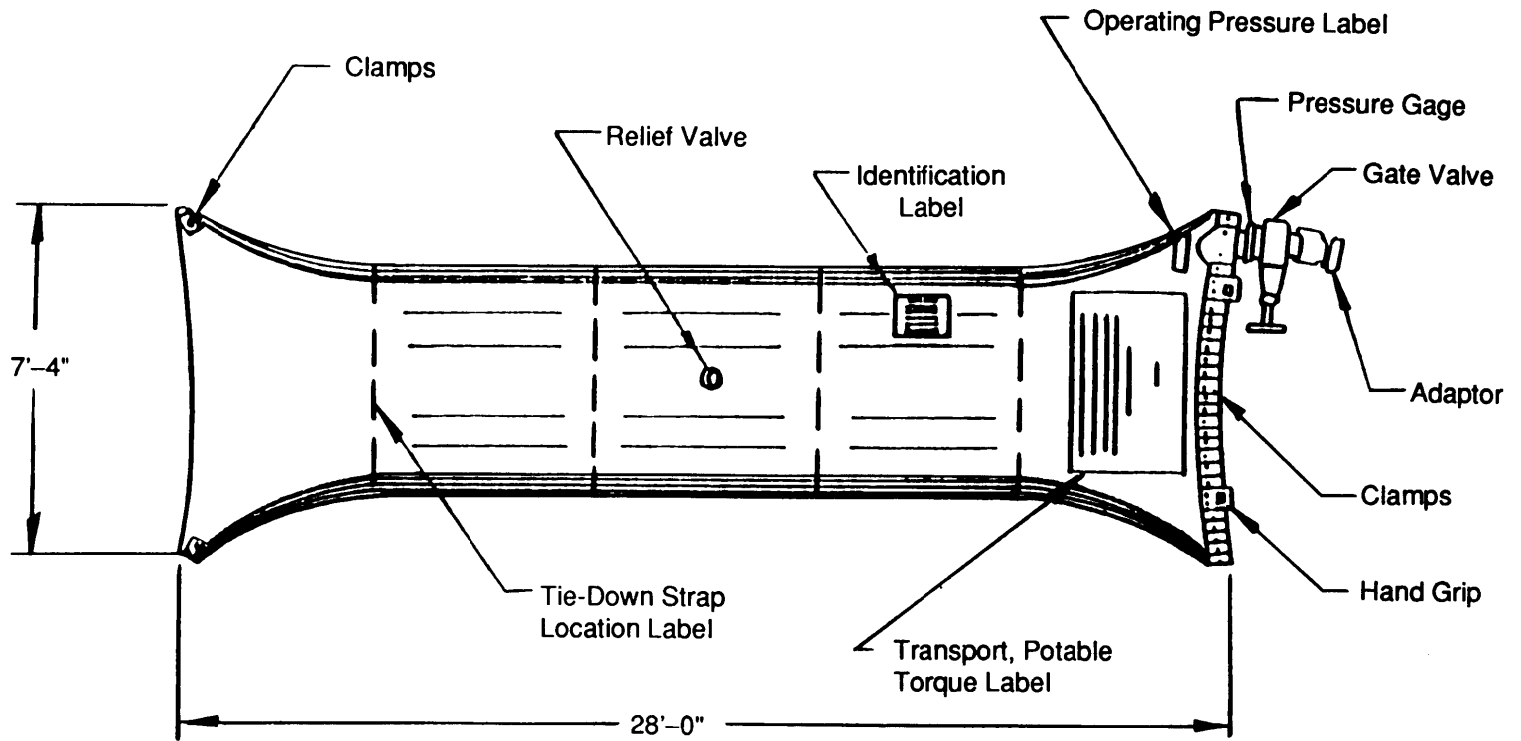

3,000 GALLON POTABLE WATER TANK (Model No. 3,000 gallon)

FIGURE 1-1



1-3

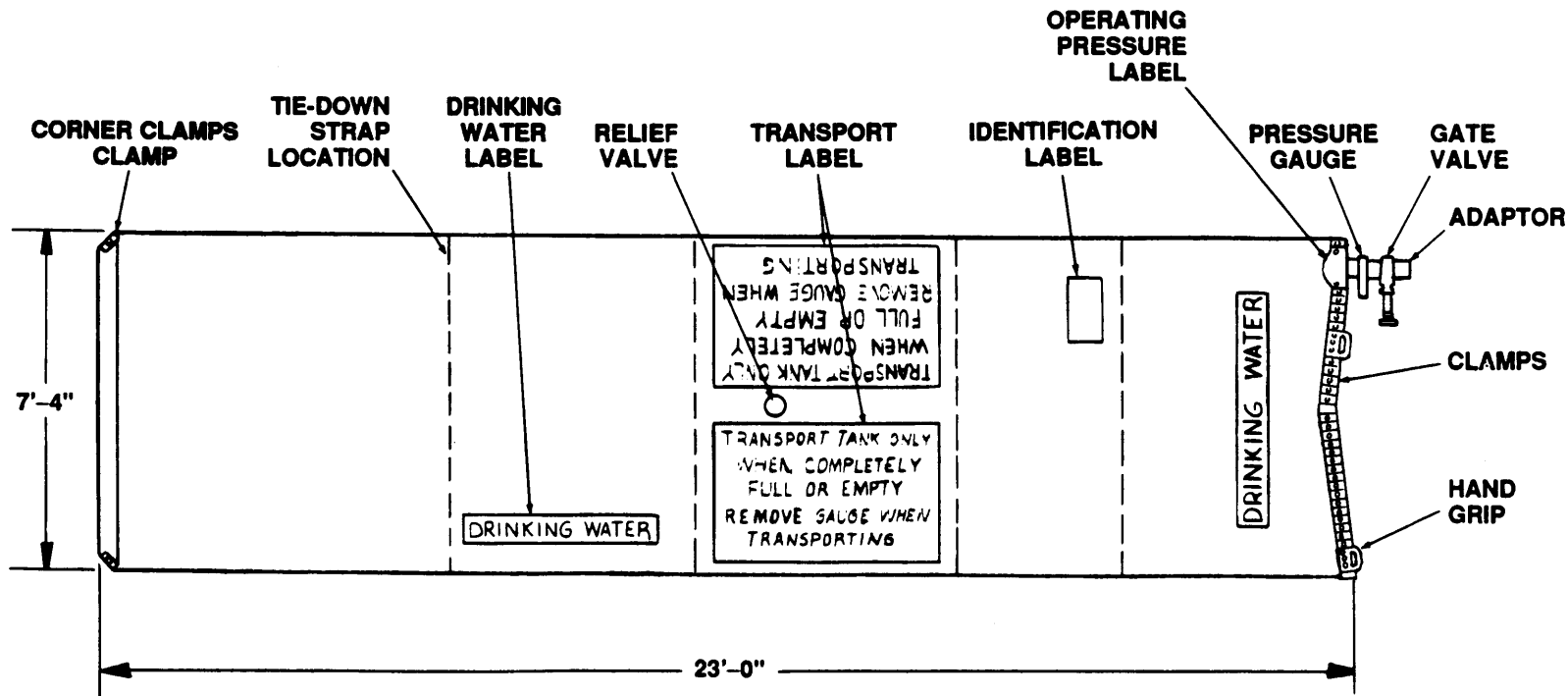

3,000 GALLON POTABLE WATER TANK (MODEL 91093)

FIGURE 1-1A

Change 4

b. Fittings

The tank is furnished with a four-inch filler/discharge assembly consisting of a male quick-disconnect, a 4" gate valve, and a pressure gage, two 10 foot lengths of hose, and a manual operated relief valve located in the top center of the tank.

c. Tie-down Assembly

The tie-down kit consists of four belts with eight ratchet take-up mechanisms, and trailer attachments specifically designed to minimize tank movement during transport.

d. Emergency Repair Items

The emergency repair kit includes temporary repair items, such as plugs and clamps, to institute an emergency repair.

1-6. Tabulated Data

a. General

Manufacturer	UNI ROYAL PLASTICS CO., INC.	AMFUEL
Model	3,000 gallon	91093
Capacity	3,000 gallons	3,000 gallons
NSN	5430-01-181-4071	5430-01-372-6901
Serial No. Range	9001-9222	
Contract Number	DAAK01-85-C-B195	DAAK01-92-C-0150

b. Dimensions and Height

Dry Dimensions	28"L x 7' 4"W x 4"H flat
Filled Dimensions	27"L x 62"W x 52"H
Dry Weight	Tank:600 lbs. approx.
Crated Weight	1,060 #
Crated Dimensions	135" x 37" x 28"

1 - 7. Identification Plate (Model No. 3,000 gallon)

The following information shall be molded onto a label and shall be bonded to the tank:

TANK, FABRIC, COLLAPSIBLE:
3,000 GALLONS, POTABLE WATER
NSN: 5430-01-181-4071
SERIAL NO: 9001-9222
MFG. UNI ROYAL, WARSAW, INDIANA
WEIGHT EMPTY: 600 LBS. APPROX.
CONTRACT NO: DAAK01-85-C-B195

1-7.1 Identification Plate (Model 91093)

The following information shall be molded onto a label and shall be bonded to the tank:

TANK, FABRIC, COLLAPSIBLE:
3,000 GALLONS, POTABLE WATER
NSN: 5430-01-372-6901
SERIAL NUMBER
MFG. AMFUEL, MAGNOLIA, ARKANSAS
WEIGHT EMPTY: 600 LBS. APPROX.
CONTRACT NO: DAAK01-92-C-0150

1-8. Information Plate (Model No. 3,000 gallon)

The following information shall be located on the tank. (See Fig. 1-1).

"TORQUE 70±5 FT - LBS"

"POTABLE WATER"

"TRANSPORT ONLY WHEN COMPLETELY FULL OR EMPTY"
OPERATING PRESSURE 5±1 PSIG
TIE-DOWN STRAP LOCATIONS

1-8.1 Information Plate (Model 91093)

The following information shall be located on the tank. (See Fig. 1-1A).

"TORQUE 70 ± 5 FT - LBS"

"DRINKING WATER"

"TRANSPORT TANK ONLY WHEN COMPLETELY FULL OR EMPTY.
REMOVE GAUGE WHEN TRANSPORTING."
OPERATING PRESSURE 5±1 PSIG
TIE-DOWN STRAP LOCATIONS

CHAPTER 2

OPERATING INSTRUCTIONS

Section I. Service Upon Receipt of Material

2-1. General

When a new or used tank is received by an organization it must be uncrated, installed and serviced as described in paragraphs 2-2, 2-3 and 2-4.

CAUTION

REMOVE ALL PROTRUDING NAILS AND OTHER OBJECTS PRIOR TO ATTEMPTING TO REMOVE THE TANK FROM THE CONTAINER. THIS IS ESSENTIAL IN ORDER TO AVOID PUNCTURING THE TANK.

2-2. Uncrating the Equipment

When the tank is received in the crate, unload it as near to its point of installation as is possible.

a. Tank

(1) Remove the nails from the crate top and remove crate top from crate. (Fig. 2-1).

(2) Using a lifting device (such as forklift), grab hold of the lift straps of the sling and carefully lift tank out of crate and transport it to its designated point of installation.

b. Repair Items and Accessories

The repair items (plugs, clamps, etc.), are in a box at the end of the crate. These should be placed in a secure place until needed. Tie-down assembly and pressure gage are packaged in the duffle bag.

2-3. Installation

The tank is to be installed on the flatbed of an M872, M871 or M127 semi-trailer. The sequence of complete assembly is as follows:

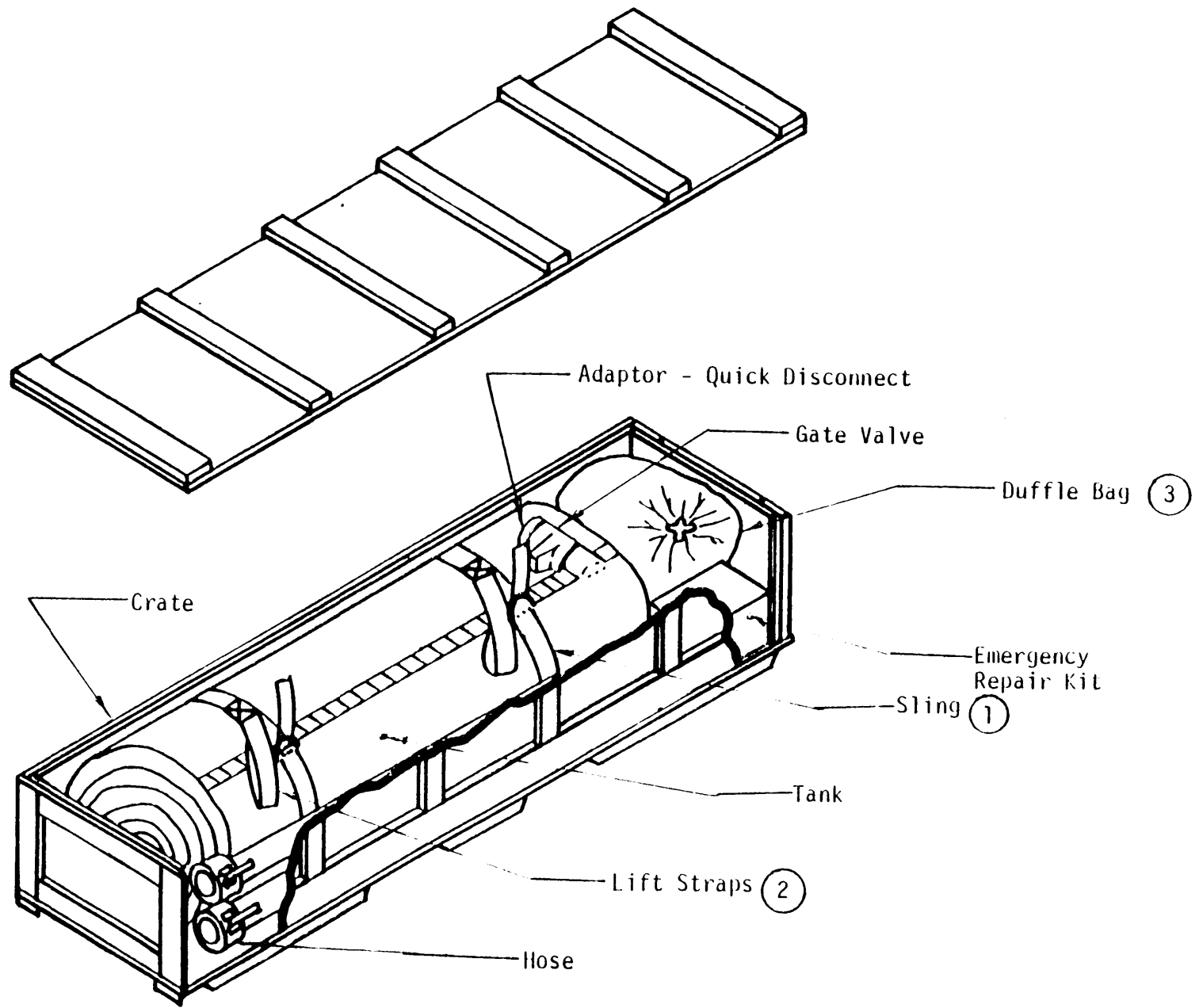

CRATED ASSEMBLY

FIGURE 2-1

a. Installation of Tie-down Kit

- (1) Clear truck bed of splinters, protruding nails and other foreign objects that could puncture or chafe the tank. Place bed cloth on truck bed forward; unroll to rear (Model 91093).
- (2) Secure the tank to the trailer with a four-belt tie-down kit. This kit is made and assembled in accordance with Figs. 2-2 through 2-6. There are two anchor points (Fig. 2-3) per belt to provide maximum support to the tank during transport. Each anchor point consists of a 5/8" diameter eyebolt, two retaining plates, one 5/8" hex nut, one lockwasher, and one flat washer as shown in Figures 2-2 or 2-3.
- (3) Locate the belt locations as shown in Figs. 2-4, 2-5 or 2-6 (depending on trailer type) and install anchor assembly as shown in Figures 2-2 and 2-3. Re-check the area for sharp objects. If the surface is rough and jagged, it will be necessary to place plywood or a tarpaulin down for the tank to rest upon.
- (4) Attach the ratchet take-up mechanism to each anchor point by using a shackle between the eyebolt and delta ring on the ratchet take-up mechanism.
- (5) Lay the tie-down straps crosswise to the length of the semi-trailer bed. Make sure the belts are centered accurately between the eyebolts. Let the remaining portion of the belts lay over the side of the trailer. Care should be taken to insure that each strap is not twisted and is laying flat. The area is now prepared for tank unfolding.

b. Installation of Tank on Trailer Bed

- (1) Using a lifting device, such as a forklift or crane, carefully take hold of the sling by its lift straps (Fig. 2-1) and place the tank on the semi-trailer in such a manner that the tank will unroll towards the rear of the trailer. The tank ends should be near or touching the trailer bulkhead.
- (2) Remove the straps from the buckles on the sling assembly and unroll and unfold the tank over the tie-down straps. Visually inspect tank while unrolling. Position it so that when it is full, the ends or sidewalls of the tank will not rub against the forward bulkhead or hang over the sides of the trailer. Remove the sling assembly from under the tank and place it in the trailer stowage compartment.

2-4 Inspecting and Servicing the Equipment

- a. Inspect the tank body for any punctures or tears.
- b. Inspect the fittings and components for evidence of damage or missing bolts or gaskets.

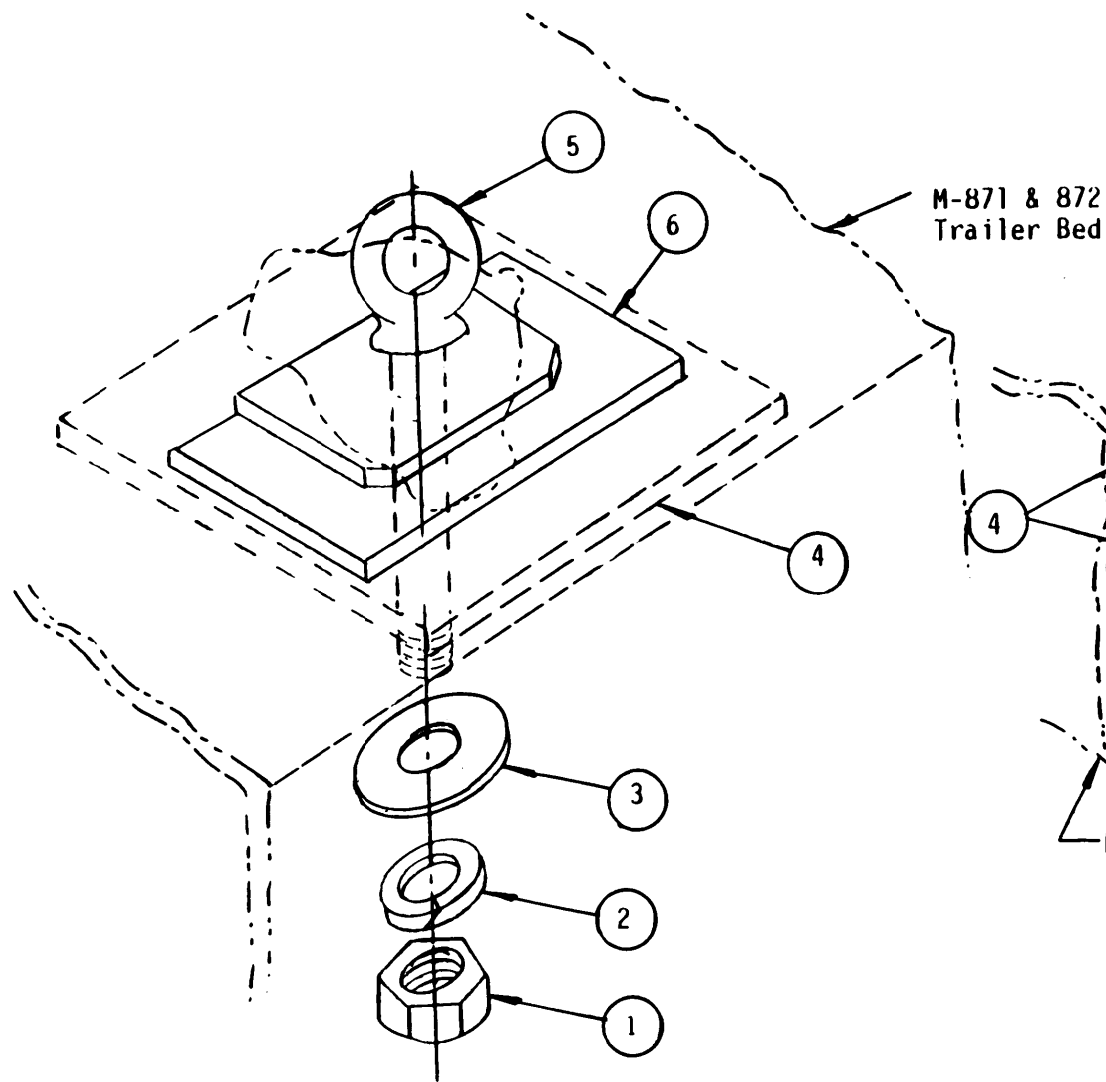

- 1. Nut
- 2. Lock Washer
- 3. Flat Washer
- 4. Retaining Plate (Bottom)
- 5. Eye Bolt
- 6. Retaining Plate (Top)

FIGURE 2-2

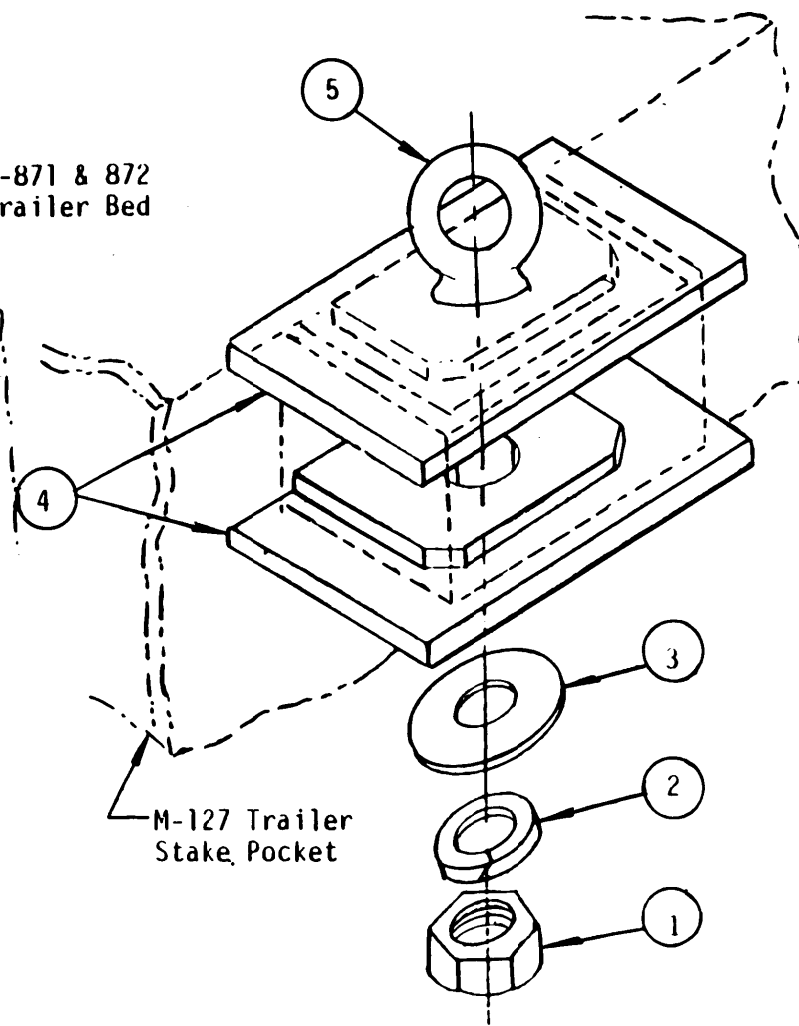

- 1. Nut
- 2. Lock Washer
- 3. Flat Washer
- 4. Retaining Plates
- 5. Eye Bolt

FIGURE 2-3

A. BELT LOCATION (M-127 TRAILER)

Use stake pockets in trailer bed to attach belts at locations shown.

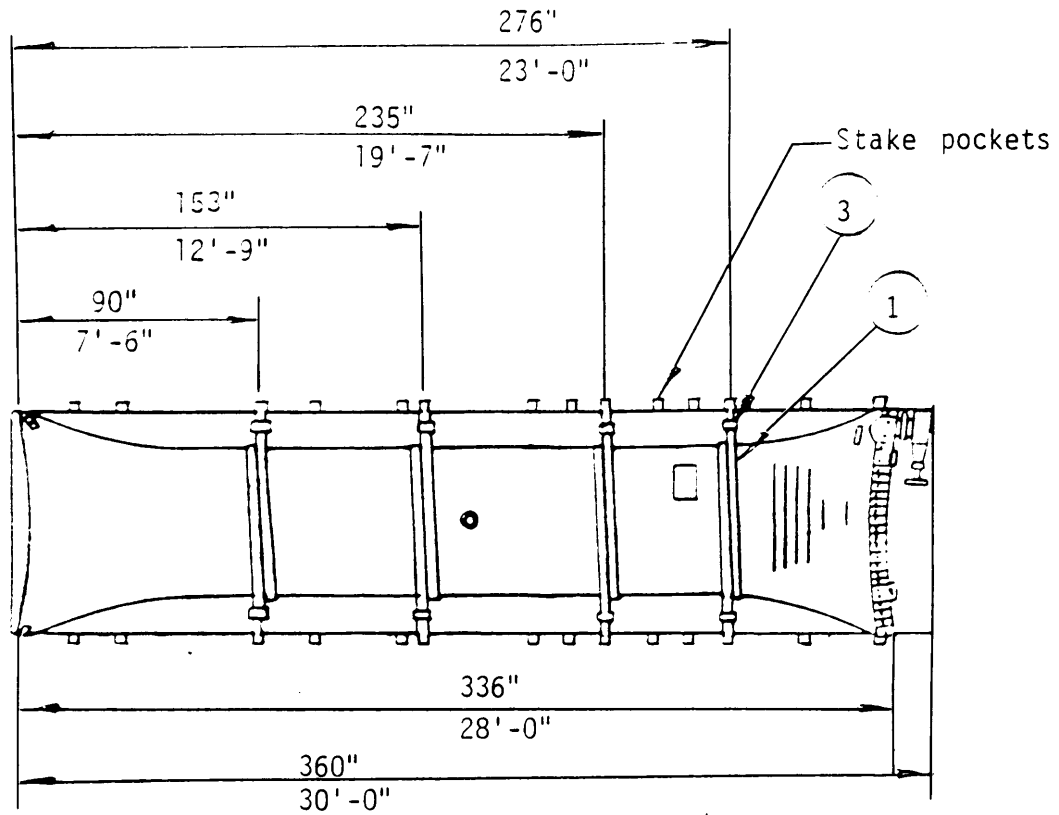

1. Belt
2. Shackle
3. Ratchet take-up assembly

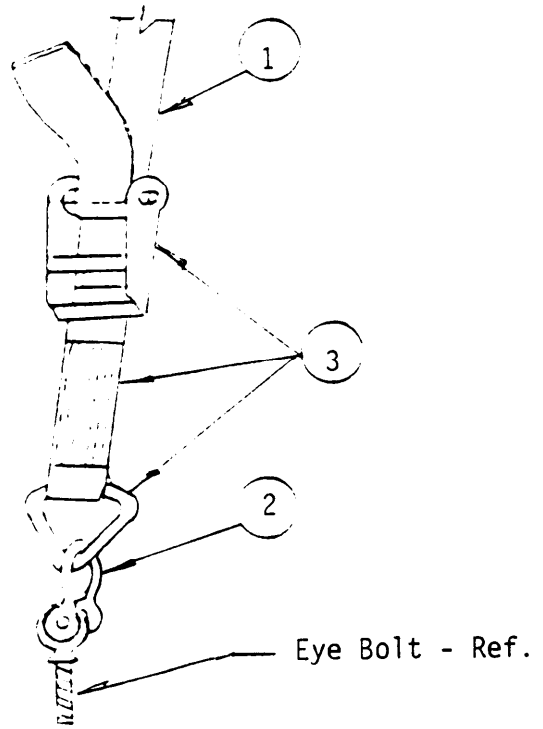
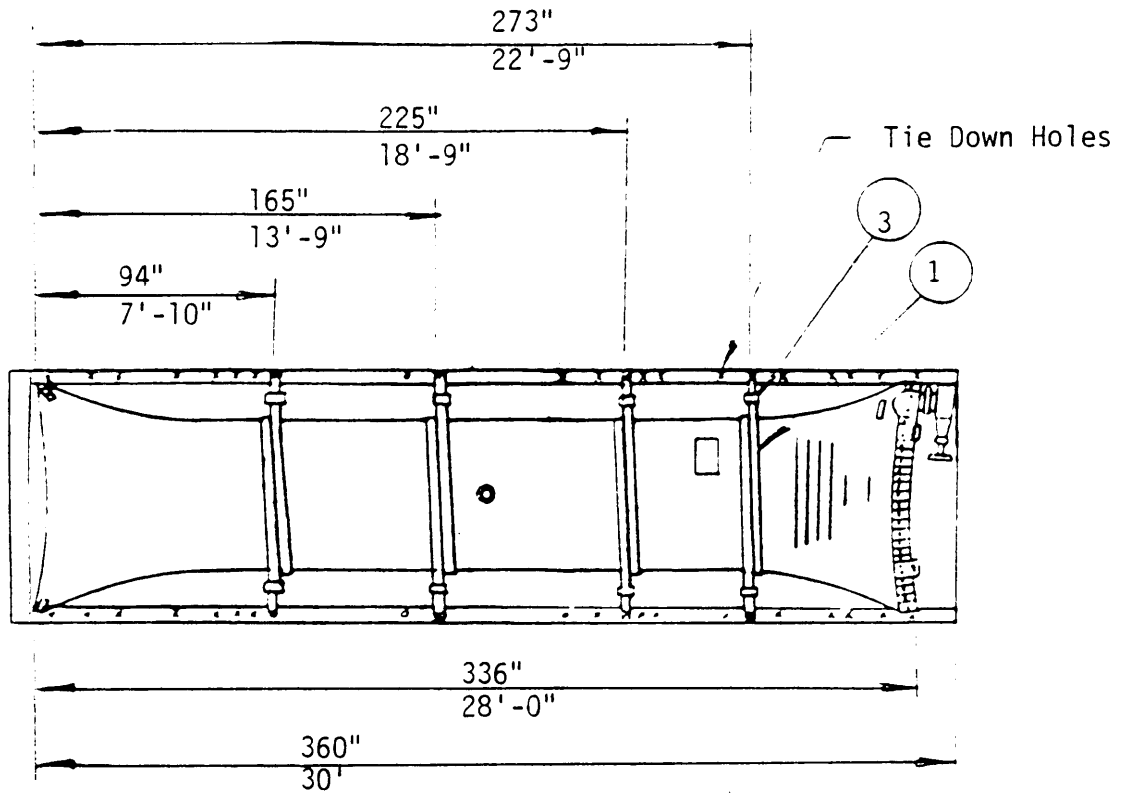

FIGURE 2-4

A. BELT LOCATION (M-871 Trailer)

Use holes in trailer bed to attach belts at location shown.



- 1. Belt
- 2. Shackle
- 3. Ratchet take-up assembly

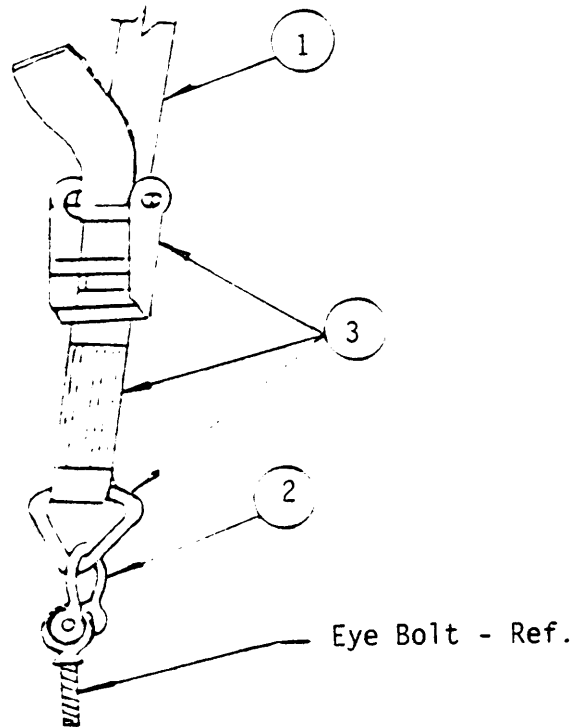
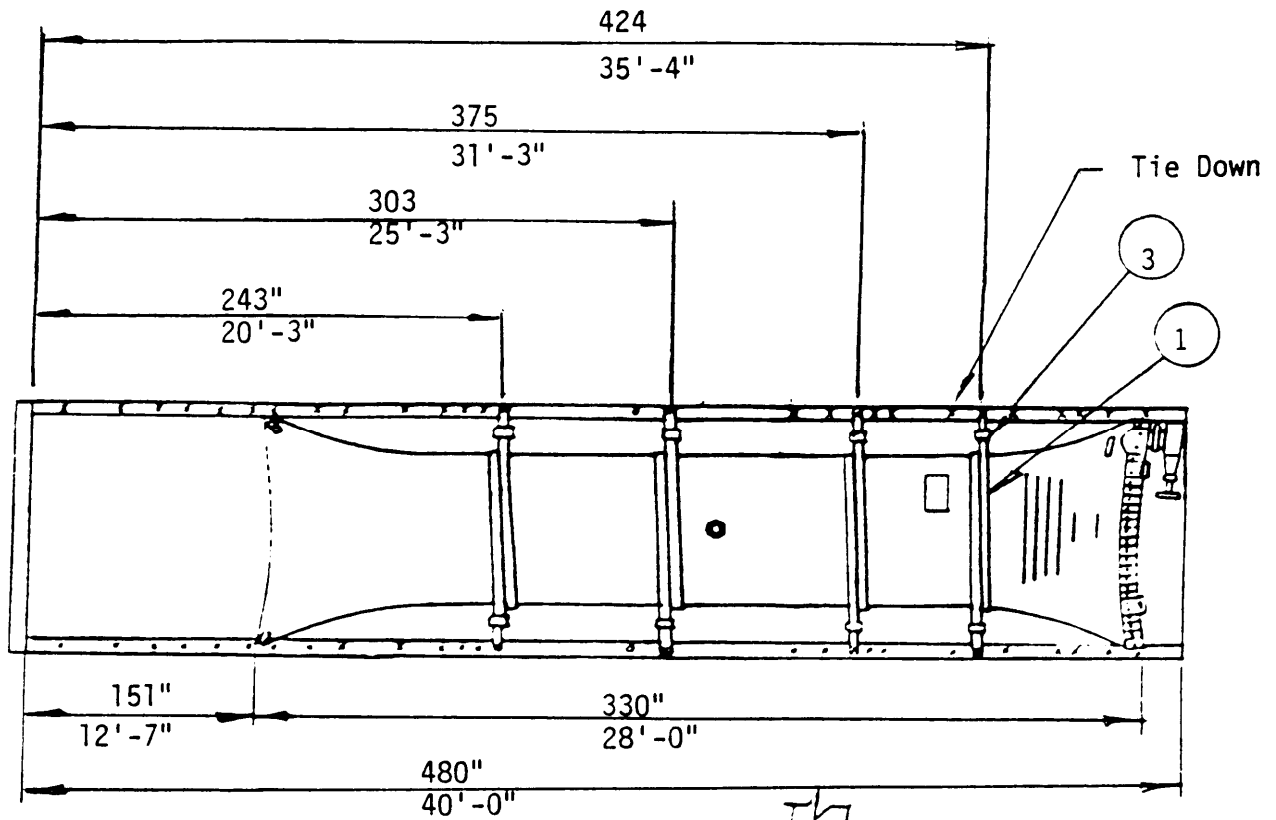

FIGURE 2-5

A. BELT LOCATION M-872 TRAILER

Use holes in trailer bed to attach belts at location shown.



- 1. Belt
- 2. Shackle
- 3. Ratchet Take-Up Assembly

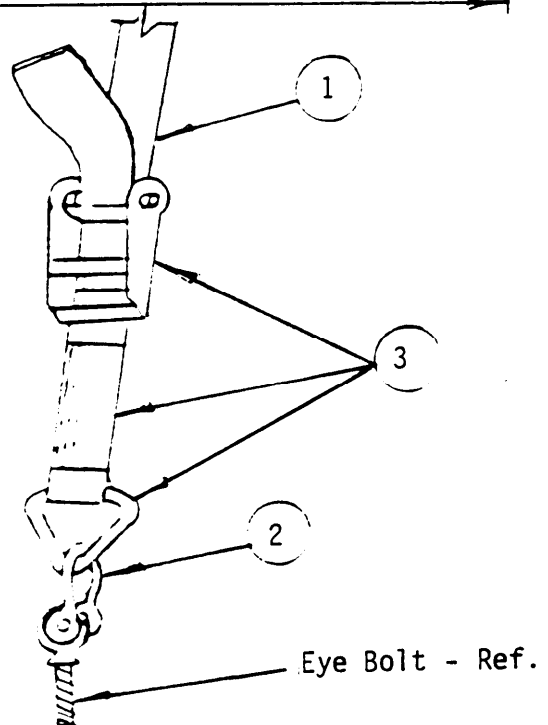

FIGURE 2-6

2-5. Correction of Deficiencies

Treat deficiencies found during initial inspection as follows:

- a. Correct deficiencies within the scope of organizational maintenance before the tank is placed in service. Tears or punctures in the tank walls may be temporarily repaired by following the instructions in Chapter 3, Section III, paragraph 3-5.

NOTE

Do not attempt unauthorized repairs.

- b. Bring serious deficiencies, or deficiencies beyond the scope of this manual to the attention of your supervisor.

Section II. **Controls and Instruments**

2-6. General

The operator should be thoroughly familiar with the location and function of every control before operating the system. Other personnel comprising the crew should be thoroughly briefed in the operation of the system and be familiar with any shutdown or stopping procedures under emergency conditions.

2-7. Filler/Discharge Valve

The filler/discharge valve is a 4" gate valve which, together with the hose assembly, provides the connection necessary to both fill and empty the tank.

2-8. Pressure Gage

A 0-15 PSI pressure gage is supplied to monitor the pressure of the filled tank. Operating pressure is 4 to 6 PSI. See Item 1, Fig. 2-7.

2-9. Pressure Gage Valve

The pressure gage is controlled by a ¼ NPT valve. The valve is to be closed when the pressure gage is removed. See Item 3, Fig. 2-7.

2-10. Hose Assembly

The hose assembly consists of two 10' long x 4" diameter potable water hose--FDA approved--supplied with quick disconnect fittings.

2-11. Pressure Relief Valve

The pressure relief valve is manually operated to relieve trapped air. It is open and closed with finger pressure.

Section III. Operating Instructions Under Usual Conditions

NOTE

DO NOT WALK UNNECESSARILY ON THE TANK AND ONLY DO SO WITH SOFT SOLED SHOES. DO NOT DROP SHARP OBJECTS ON TANK, SUCH AS WRENCHES, FITTINGS, ETC.

WARNING

IF EQUIPMENT FAILS TO OPERATE, REFER TO TROUBLE SHOOTING PROCEDURES IN CHAPTER 3.

2-12. Filling Tank

- a. Check to see that the tank is properly installed. The trailer bed should be level to prevent the tank from rolling.
- b. Tighten all the cap screws to 70 ± 5 ft. lbs. torque on the end clamp bolts. The rubber in new tank will "cold flow" under the pressure and the torque will drop. Tanks should be re-torqued periodically until the rubber has set and the torque doesn't drop appreciably. If leakage is noted at the fittings or if the tank is subjected to hard usage, cap screws should be re-tightened periodically.
- c. Attach the pressure gage to the filler/discharge valve as **shown in Fig. 2-7**. Then open the pressure gage valve. (3, Fig. 2-7).

NOTE

Before using the tank for the first time or prolonged storage, flush the tank with 100 to 300 gallons of clean disinfectant and water solution. The solution consists of 1/2 gallon of commercial bleach mixed in 250 gallons of fresh water. Surge the cleansing solution by walking back and forth on the tank or by rocking the truck with abrupt starts and stops. The resultant surge will clean the collapsed tank without exposing its interior to contaminants' or foreign objects.

Rinse tank with 250 gallons water to remove bleach taste.

When the cleaning is complete, close the tank valve immediately to hermetically seal out contaminants.

- d. Before starting to fill the tank be sure that all air has been expelled. Then close 4" tank inlet valve.
- e. Attach source of water to the supplied 4" diameter hose. Purge the air from the filling line and the hose by opening the valve at the water source until the water comes out the supplied hose. Turn off water at the water source.

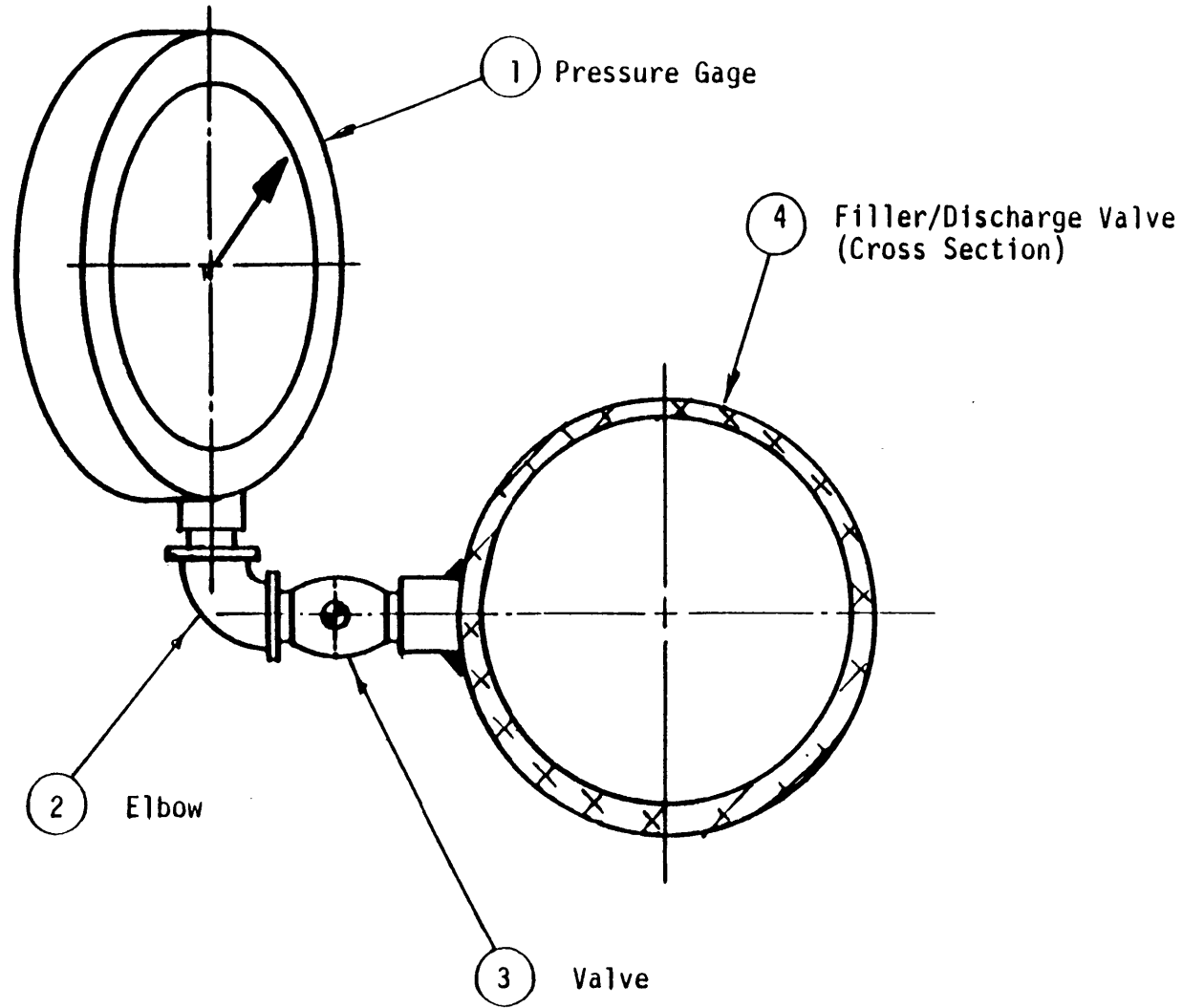

PRESSURE GAGE ASSEMBLY

FIGURE 2-7

- f. The free ends of the hold-down belts should now be brought over the top of the tank and down the other side through the ratchet take-up mechanism attached to the truck bed. Slide ends of belt 2 feet through slot in ratchet assembly. Fold end back on belt and hold manually until one turn has been taken **on** roll-up spool.
- g. Attach the hose to the tank fill/discharge valve.
- h. Open the valve at the potable water supply.
- i. Open the filler/discharge valve on the tank.
- j. No pressure will show on the pressure gage until the tank is approximately two feet high. From that point on periodically check the exact tank pressure by closing the 4" filler/discharge valve on the tank to obtain a precise tank pressure reading.
- k. After pressure reading has been taken, open the 4" filler/discharge valve on the tank and resume filling to 2 to 3 PSIG.
- l. Open the relief valve on the top of the tank until water flows from the valve.
- m. The belts should now be tightened with the ratchet handle. Tighten belts to the maximum possible with one hand on the ratchet handle. **The second hand should be used to steady the ratchet assembly so that the belt will wind flat and true. After tightening each ratchet assembly, see that the ratchet handle has dropped** securely into the locking mechanism. When all ratchet assemblies have been tightened uniformly, the pressure in the tank will be increased approximately ½ PSI.

NOTE

If the tank ends are not level with the floor of the trailer the tank may be leveled by releasing the ratchet on one side of the tank and then taking **up the slack by tightening the opposite ratchet.**

- n. **After filling the tank to correct pressure (4-6 psi), shut off** filling line valve first, then shut off tank filler/discharge valve. Disconnect filling line. Some loss of water between the valves will be experienced at this point. Material is under pressure between the valves; low pressure if the filling line valve is shut off first as directed above, and high pressure if the tank valve is shut off first.

NOTE

The closed system of filling a tank allows the pressure to build up very rapidly as the tank reaches full capacity. **It is recommended that tank containers be filled to a final minimum pressure of 4 PSI and a maximum of 6 PSI.**

- o. Keep pressure gage valve (3 Fig. 2-7) open to allow continual observation of tank pressure.
- p. Tank is now properly filled and secured for transportation. Regular periodic checks for tight belts is recommended. They should be tightened at least every two hours. Tank must be transported only when completely full or empty.

2-13. Draini ng

WARNING

TANK IS DESIGNED TO BE EMPTIED BY GRAVITY OR SUCTION PUMP ONLY. USE OF AIR PRESSURE TO UNLOAD TANK IS NOT AUTHORIZED AS IT MAY CAUSE THE TANK TO BURST UNDER PRESSURE.

- a. The tank can be drained either by gravity or by the use of a pump.

- b. Drain by Gravity

- (1) The end of the tank **opposite the valve must be at least 8"-10" higher than the valve end of the tank.** For complete tank draining this is necessary. **The valve corner should be the lowest level of the tank.** Use grade elevation or portable ramps under the appropriate trailer wheels.
- (2) Connect one end of the 4" diameter hose assembly to the tank filler/di scharge **valve.**
- (3) Connect the other **end of the hose to the line or container requiring the potable water.**
- (4) Close the tank pressure gage valve.
- (5) Open the filler/di scharge valve on the tank to start the flow.
- (6) After operation is **complete close filler/di scharge valve on end of tank.**

- c. Draini ng by Pump

- (1) Connect one end of the 4" diameter hose assembly to the tank filler/di scharge valve.
- (2) Connect the other end of the hose to the line from or directly to the pump.
- (3) Close the tank pressure gage valve.

- (4) Open the tank filler/discharge valve.
- (5) Start pump. Draining rate is not a factor in tank operations.
- (6) After operation is complete close the tank filler/discharge valve.
- (7) close the valve on the pump.
- d. Disconnect the 4" diameter hose assembly from the line, container or vacuum pump, whichever is applicable.
- e. Disconnect hose from tank filler/discharge valve.

2-14. Re-packing (Figure 2 - 8)

- a. Remove pressure gage.
- b. Disconnect hold-down kit ratchets and remove. Hang loose ends of belt over sides of trailer.
- c. Fold tank almost in half lengthwise. Lay top fold of the tank down approximately 1 foot shorter than bottom fold. The ends will then be equal when the tank is rolled.
- d. Roll manually. It is necessary that the first roll be circular and tight, otherwise the tank will be hard to roll and make a large package.
- e. The sling may be slipped around and under the tank if the tank is to be transported to a new location or placed back in its shipping box. The sling is located in the semi-trailer storage compartment. Fold bed cloth (Model 91093 only).
- f. Roll and store belts, pressure gage, ratchets, bolts and plates, etc. in prepared area, preferable in a box. Pad pressure gage to avoid damage.
- g. After the first few uses, the tank will become more flexible and easier to roll and unroll.

Section IV. Movement to and from Worksite

2-15. General

- a. When tank is full, before movement, tank should be lashed to trailer with sling provided.
- b. When tank is empty, before movement, tank should be rolled up and lashed securely to trailer.
- c. When tank is not in use, unit assemblies and components should be disassembled, dried, cleaned and preserved for future use.

Section V. Operating Under Unusual Conditions

2-16. General

The potable water tank is designed to operate in exterior temperature conditions ranging from -25°F to 160°F.

2-17. In Extreme Cold

- a. Keep ice and snow accumulation from the top of the tank.
- b. All ice and snow must be removed from the quick-disconnect connections to insure proper assembly and disassembly.
- c. Avoid any unnecessary folding, unfolding or rolling of the tank which might cause cracking or damage to the material.

2-18. In Extreme Heat

If possible, set up protective shades over the tank and its components, being careful not to block air circulation.

2-19. Operating in Dusty or Sandy Areas

- a. Keep all components clean, particularly at sealing and connecting parts.
- b. Keep all hoses and fittings covered with plugs or caps when not in use.
- c. Cover all system components when not in use.

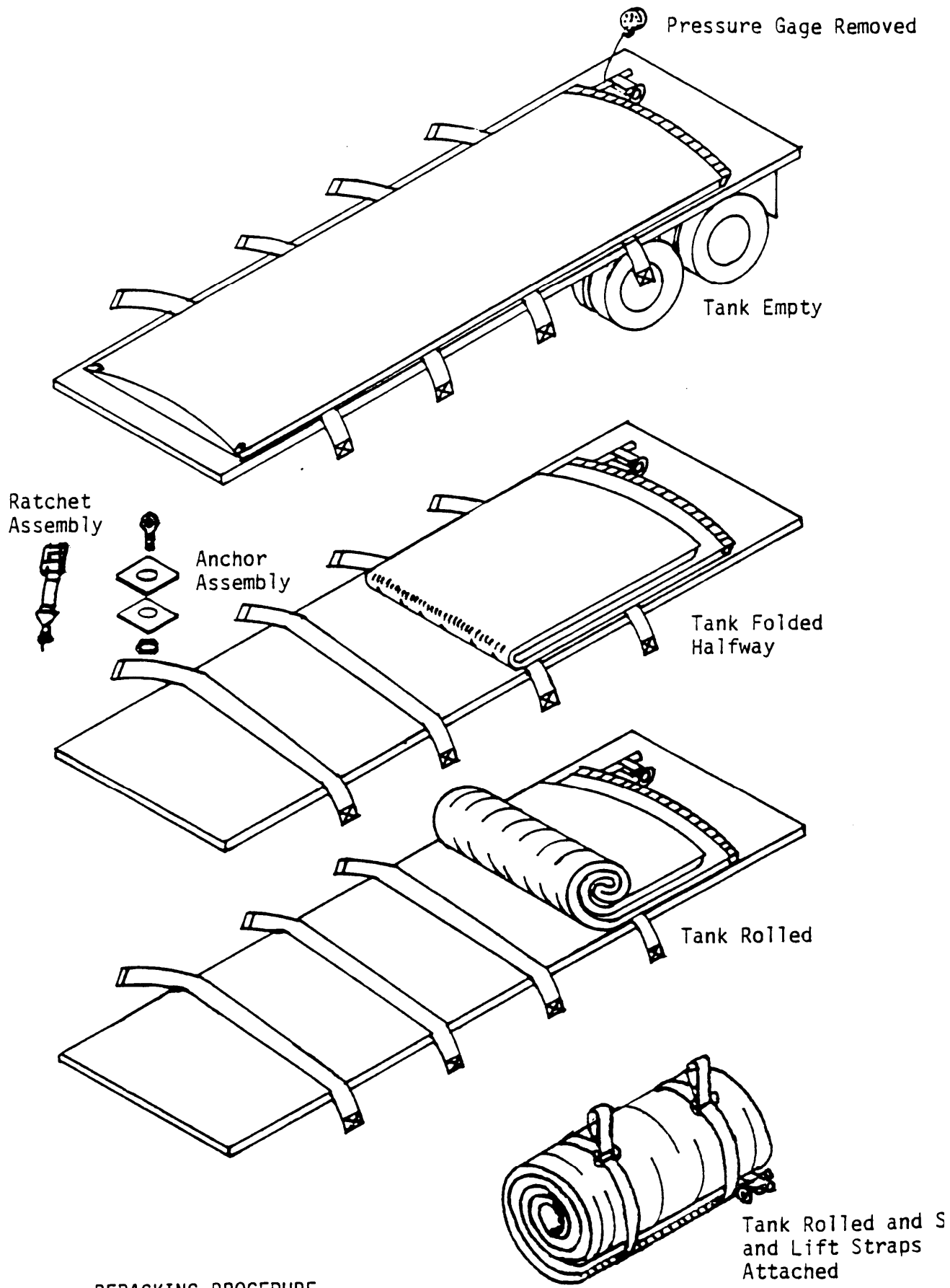

REPACKING PROCEDURE
 FIGURE 2-8

CHAPTER 3

MAINTENANCE INSTRUCTIONS

Section I. Introduction

3-1. General

The necessary preventive maintenance services to be performed are listed and described in Table 3-1.

WARNING

STOP OPERATION IMMEDIATELY IF A DEFICIENCY OCCURS WHICH COULD CAUSE DEATH OR SERIOUS INJURY TO PERSONNEL.

Table 3-1. Operator/Crew Preventive Maintenance Checks and Services

B - Before operation

D - During operation

A - After operation

Item No.	Interval			Item to be Inspected Procedure
	B	O	A	
1	•	•		<u>Installation Area</u> Inspect the semi-trailer to prevent accumulation of stones, sticks, and other sharp objects that might cause punctures and leaks.
2	•	•	•	<u>Tank Body</u> Inspect tank body for tears, punctures and leaks.
3	•	•	•	<u>Filler/Discharge Assembly</u> Inspect filler and discharge assemblies for evidence of damage or leakage.
4	•		•	<u>Bed Cloth</u> (Model 91093 only) Inspect bed cloth for damage.

Section II. Troubleshooting

3-2. General

- a. This section contains troubleshooting information for locating and correcting most of the operating troubles which may develop in the tank system. Each malfunction for an individual component, unit or system is followed by a list of tests or inspections which will help you determine probable causes and corrective actions to take. You should perform the tests/inspections and corrective actions in the order listed.
- b. This manual cannot list all malfunctions that may occur, nor all tests or inspections and corrective actions. If a malfunction is not listed or is not corrected by listed corrective actions, notify your Supervisor.

Table 3-2. Troubleshooting

MALFUNCTION	TEST OR INSPECTION	CORRECTIVE ACTION
1.	<u>Tank Leaks</u>	Inspect the tank for punctures or cuts. Refer to Paragraph 3-5 for emergency or permanent repair.
2.	<u>Filler/Discharge Valve Assembly Leaks</u>	Step 1. Check for loose cap screws on clamping plates. (13 Fig. C-1). Tighten bolts to 70- 5 ft. lbs. Step 2. Quick connect adapter (10 Fig. C-1) is loose. Tighten adapter.
3.	<u>End Fitting Assembly Leakage</u>	Step 1. Check for loose cap screws on Clamping Plates (Fig. C-1). Tighten all cap screws to 70+/- 5 ft. lbs. (Para. 3-6). Step 2. Check for damaged clamps. Replace top and/or bottom clamps. (Para. 3-6).
4.	<u>Pressure Gage Fails to Operate</u>	Check for bent indicator. Remove and blow in end of gage. Replace if necessary. (Para. 3-7).
5.	<u>Ratchet Take-up Mechanism Fails to Operate</u>	Check for broken parts. Replace parts as necessary (Para. 3-8).
6.	<u>Pressure Relief Valve Leaks</u>	Check for loose nut (Paragraph 3-11).

Section III. Maintenance Procedures

- 3-3. General
This section contains maintenance and repair instruction for the 3, 000 gallon potable water tank.

3-4. Visual Inspection Procedure

Tanks should be visually inspected every three to six months, depending upon frequency of use.

- a. Position tank on a clean, smooth surface, so that it is easily accessible on all sides.
- b. Inflate the tank to shape (approximately 1 **PSI**).
- c. Inspect hardware for damage and sharp edges. Sharp edges should be filed smooth to prevent damage to the tank body. Damaged hardware should be replaced. (Paras. 3-6 and 3-7).
- d. Torque all bolts on clamp fittings. Use 70 ± 5 ft. lbs.
- e. Inspect tank body by rolling from side to side. Carefully inspect for cuts, tears, bruises, chafe marks, loose edges, or any surface looseness.
- f. Whenever damage is discovered, even if it extends only through the external covering, repairs should be made at once.

3-5. Emergency Temporary Repairs (Exterior)

a. Emergency Repairs with Sealing Clamps

- (1) Small slits, tears or cuts (not to exceed $6\frac{1}{2}$ inches in length) will be repaired with sealing clamps. (Fig. 3-1).
- (2) The size of the damaged tank area (opening) needing repair govern the size and applicability of the clamp to effect a tank repair. The following criteria is furnished as guidance in selection of appropriate size clamp:
 - (a) For holes (tears) up to 2 inches in length, install the 3 inch sealing clamp.
 - (b) For holes (tears) 2 to 4 inches in length, install the 5 inch sealing clamp.
 - (c) For holes (tears) 4 to $6\frac{1}{2}$ inches in length, install the $7\frac{1}{2}$ inch clamp.
- (3) It may be necessary to increase the size of the tears slightly with a pocket knife in order to be able to insert the bottom plate of the sealing clamp.
- (4) Slip the bottom plate of the sealing clamp through the hole or tear and rotate it until it is centered and parallel to the **tear**.
- (5) Center the top plate of the sealing clamp on the threaded shank and directly over the bottom plate.

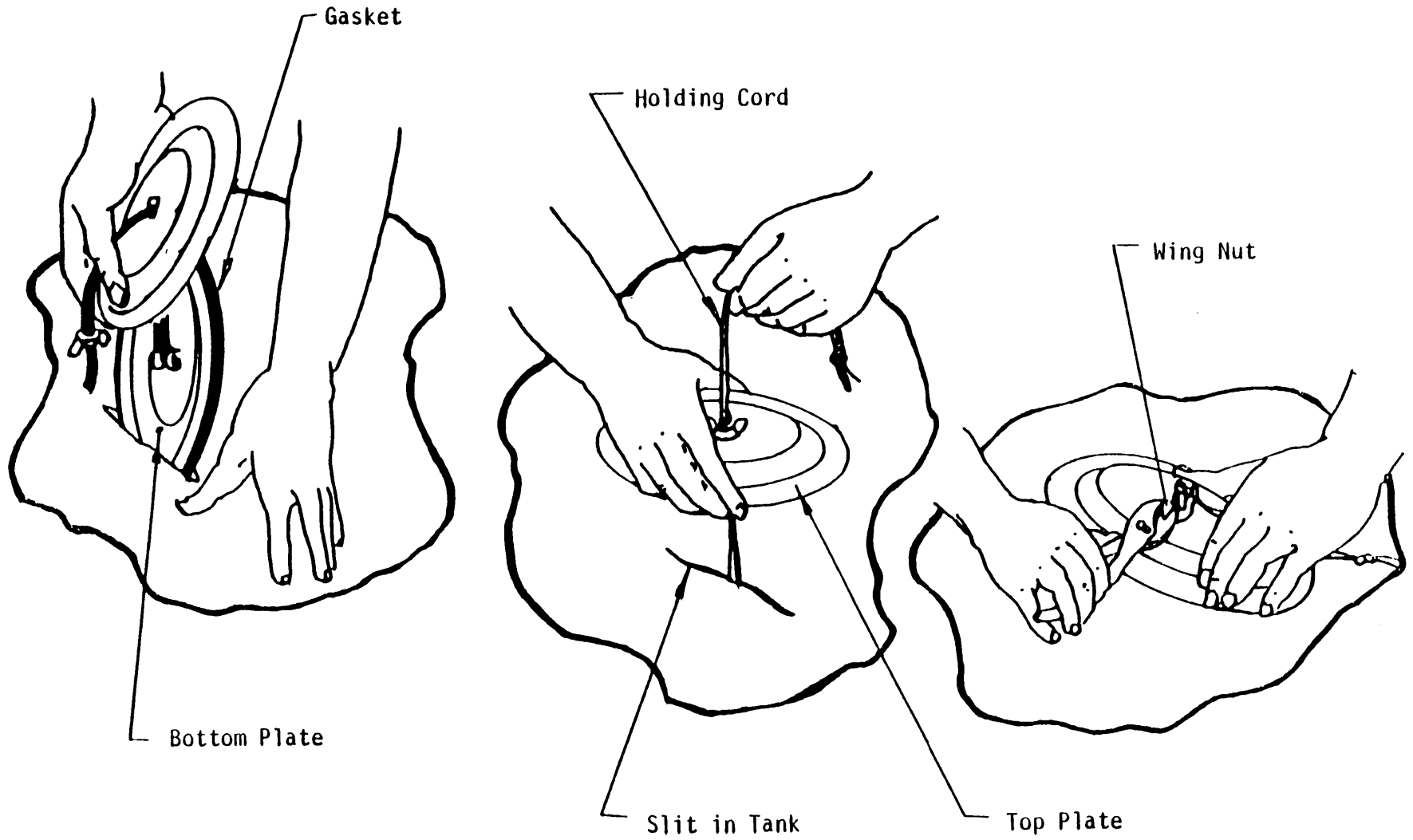

INSTALLATION OF SEALING CLAMPS

FIGURE 3-1

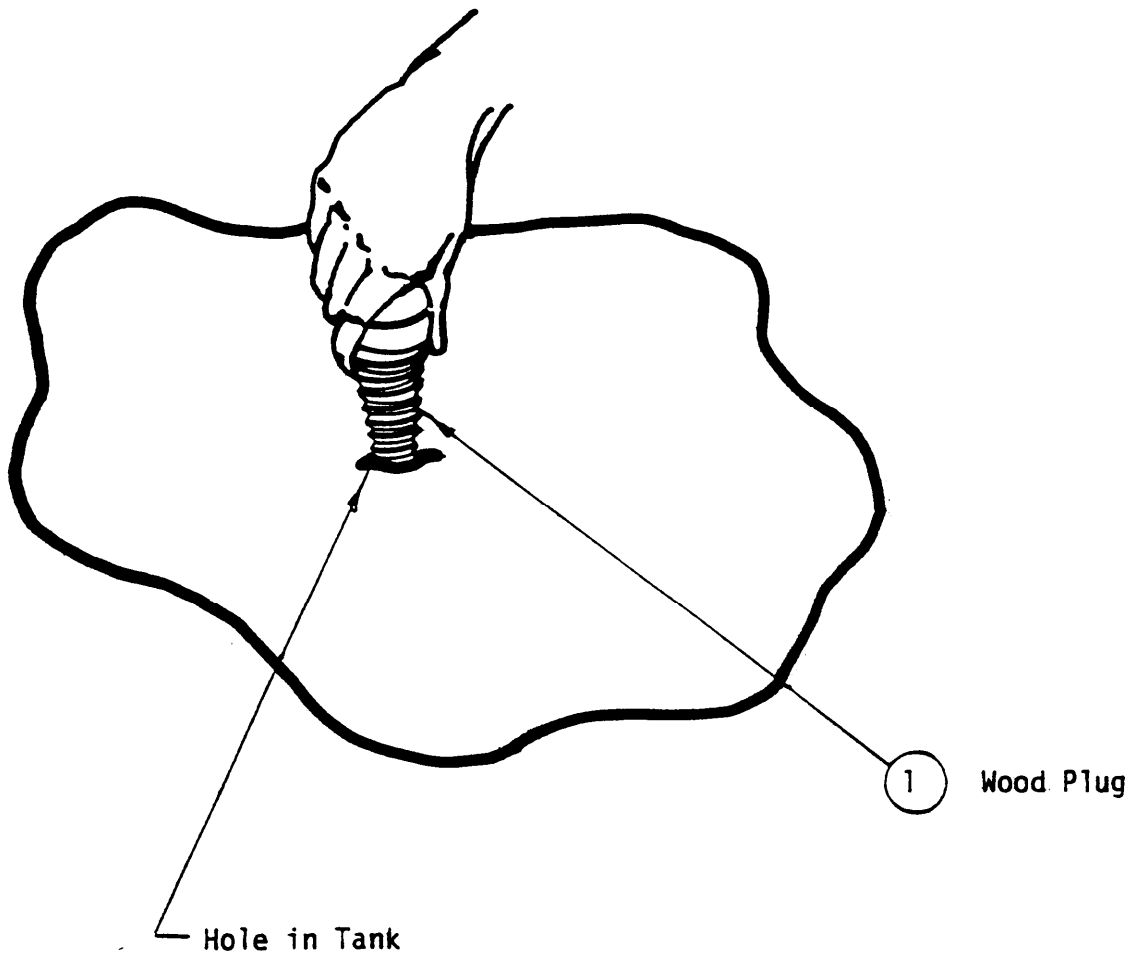

INSTALLATION OF WOOD PLUG

FIGURE 3-2

- (6) Tighten the wing nut to securely clamp the tank wall between the two plates. Tighten enough to stop leak. If pliers are used, DO NOT exert extreme tightening that might strip the threads of clamp stud or that might damage the tank fabric.
- (7) Remove the nylon cord, if desired.

b. Emergency Repairs With Wooden Plugs

- (1) In emergencies, as an immediate temporary measure, the furnished wooden plugs may be used for expedient sealing of small holes or punctures. (Fig. 3-2).
- (2) Select the size plug needed to fit (seal) the tank puncture, insert in the hole and twist clockwise until the fit becomes quite snug and the tank leak is either stopped or slowed to the greatest possible degree. Follow-up regular inspection should be made of the inserted plugs, as possible tightening of the plugs may be necessary if the leaks resume. Later, if a leak is not totally stopped, the use of a small repair clamp may become necessary.
- (3) The size of hole or tear will determine the size of wood plug to be used.
 - (a) For holes (tears) up to approximately 1/2 inch in size, use the 3 inch long plug.
 - (b) For holes (tears) up to approximately 1 1/2 inches in size, use the 5 inch long plug.

c. Deleted.

3-5.1 Tank Assembly

NOTE

This procedure consists of patching cuts and punctures in the tank fabric. If tank must be put back in immediate service, or materials are not available, perform emergency repairs, paragraph 3-5.a or 3-5.b. instead of this task.

There are three methods to repair tank fabric which holds water.

- Preferred Method: Patches are used on both inside and outside of tank.
- First Alternate: Single patch on inside of tank.
- Second Alternate: Single patch on outside of tank.

Fabric which does not hold water needs only one exterior patch.

- a. Ensure that all components of the repair kit (ROCTAD) (Item 1, App. E) are present and tank is empty before starting repair. See Table 3-3.

*Table 3-3. Collapsible Fabric Tank And Drums Repair Outfit Components
(OF6E1) BOV-USA-1*

DESCRIPTION	ITEM NO.	QTY
COATED FABRIC PATCHES (18 X 18 INCHES)	1	2
SCRUFFING BRUSH	2	1
Q.D. SURFACE CONDITIONER	3	2 CANS
D & A FLUID ELASTOMER BASE	4	2 CANS
D & A FLUID ELASTOMER SOLIDIFIER	5	2 CANS
MIXING STIRRER	61	
PROTECTIVE GLOVES, DISPOSABLE, SIZE LARGE	72 PAIR	
SYNTHETIC BRISTLE BRUSH, 1 INCH WIDE	8	3
CLEANING AND SOLVENT CLOTH	9	1

*Table 3-3. Collapsible Fabric Tank And Drums Repair Outfit Components
(OF6E1) BOV-USA-1 (Continued)*

DESCRIPTION	ITEM NO.	QTY
N.F. CLEANER/DEGREASER, 1 PINT	10	1 CAN
APPLICATION SPATULA	11	2
PROTECTIVE POLYETHYLENE SHEET (18 X 18 INCH)	12	1
RESPIRATOR MASK	13	2;
INSTRUCTION WITH STEP BY STEP PHOTOGRAPHS	14	1
MATERIAL SAFETY DATA SHEETS, each set has sheets for 4 chemicals	152 SETS	
RESEALABLE BAG, NON REFLECTIVE TAN	16	1
RAZOR KNIFE	17	1
MIXING BOWL	18	2

- b. Provide a smooth, firm surface (table, board, etc.) under the tank fabric to be repaired. Position the protective sheet (Item 12, Table 3-3) between the area to be repaired and the adjacent tank fabric to prevent the fabric from sticking together.
- c. Use repair patch(es) (Item 1, Table 3-3) in a size required to overlap hole at least 2 inches (5.1 cm) on all sides.
- d. If two patches (Item 1, Table 3-3) are required to cover the hole, make sure second patch overlaps first patch by 2 inches (5.1 cm).

WARNING

The cleaning fluids and adhesives in the repair kit are flammable and toxic to the skin, eyes, and respiratory tract. Skin and eye protection are required. Avoid prolonged breathing of vapors, and minimize skin contact. Protective gloves and respirator masks are part of the repair kit (Items 7 and 13, Table 3-3). Good general ventilation is normally adequate. Keep away from excessive heat, open flames, or other sources of ignition. Do not eat, drink, or smoke while using these chemicals.

Do not use the Cleaner/Degreaser near aluminum fittings on the tank. Contact of the Cleaner/Degreaser to aluminum can cause explosive gases to form. These gases can cause further damage to the tank or injury to personnel.

NOTE

Degreasing tank fabric can result in processing oils and waxes being drawn to the fabric surface. This impairs adhesion of the Fluid Elastomer (adhesive) to the tank fabric. Tank fabric should be tested for compatibility with Cleaner/Degreaser.

- e. Test the Cleaner/Degreaser (Item 10, Table 3-3) on a small area of the tank fabric.
 - (1) Moisten the cleaning cloth (Item 9, Table 3-3) with a small amount of Cleaner/Degreaser (Item 10, Table 3-3).
 - (2) Rub on a small area of the tank. If a greasy film appears, skip to step g. Otherwise go to step f.
- f. Clean entire area of tank to be patched with Cleaner/Degreaser (Item 10, Table 3-3).
- g. Undercut fine edges of the hole with razor knife (Item 17, Table 3-3). Scuff the mating surfaces of both the tank and patch(es) with scuffing brush (Item 2, Table 3-3). Roughened area on tank should extend approximately 1 inch (2.5 cm) on all sides beyond the surface where the patch(es) will be installed.
- h. Brush away loose contamination and degrease again if needed.

NOTE

One can of Surface Conditioner should cover approximately 6.5 sq. ft. (0.63 sq. meters).

All mixing and application tools should be cleaned immediately after use with Cleaner/Degreaser.

- i. Immediately brush a thin, even coat of Surface Conditioner (Item 3, Table 3-3) onto the area of tank to be patched. Use the brush (Item 8, Table 3-3) as a stipple to ensure the thinnest possible film.

NOTE

The touch dry time will be dependent on the ambient temperature and relative humidity. The touch dry time at 68°F (20°C) and 50% relative humidity will be 20 to 30 minutes. Overcoating of Surface Conditioner with Fluid Elastomer (adhesive) must take place within 4 hours.

- j. Let Surface Conditioner (Item 8, Table 3-3) set until touch dry before overcoating with mixed Fluid Elastomer (adhesive). Test by lightly touching one knuckle down into Surface Conditioner. Lift slowly. If no conditioner is left on knuckle, it is dry. If a second (outside) patch is to be applied, repeat steps g through j for outside of tank before going onto step k.

NOTE

Both the Base and Solidifier components of the Fluid Elastomer must remain sealed until just before application. For best results do not apply the mixed adhesive under the following conditions:

When the temperature is below 41 °F (50C)

When the relative humidity is above 90%

During rain, snow, fog, or mist

When there is moisture on the tank surface or moisture is likely to condense on the tank before the Adhesive cures.

When the working environment is likely to be contaminated by oil or grease from adjacent equipment or smoke from kerosene heaters or tobacco smoking.

- k. Empty entire contents of one can of the Fluid Elastomer Base (Item 4, Table 3-3) into the mixing bowl (Item 18, Table 3-3).
- l. Shake one can of the Fluid Elastomer Solidifier (Item 5, Table 3-3). Pour the contents over the Elastomer Base (Item 4, Table 3-3) in the mixing bowl (Item 18, Table 3-3).
- m. Using the mixing stirrer (Item 6, Table 3-3), immediately stir together the Fluid Elastomer Base (Item 4, Table 3-3) and Solidifier (Item 5, Table 3-3). Stir for at least 2 minutes to form an adhesive.

NOTE

Use all of the mixed adhesive within the times shown in Table 3-4

Table 3-4. Shelf Life Of Mixed Adhesive

Temperature	41 °F(50C)	59 F(15°C)	77° F(25° C)
Use All Material Within	25 minutes	20 minutes	10 minutes

- n. Using one of the brushes (Item 8, Table 3-3) or the plastic applicator (Item 11, Table 3-3), apply one even coat of adhesive to the roughened surface of the tank and the prepared patch. The coat of adhesive should be approximately 10 mil. (0.025 cm) thick.
- o. Let adhesive set until tacky (approximately 5 to 10 minutes). Test by lightly touching one knuckle into adhesive. Lift slowly. When knuckle lifts fabric briefly, and no adhesive is left on knuckle, it is tacky.
- p. Once adhesive is tacky, bring ends of patch together (adhesive side out), and position center of patch onto center of hole (Fig. 3-3).

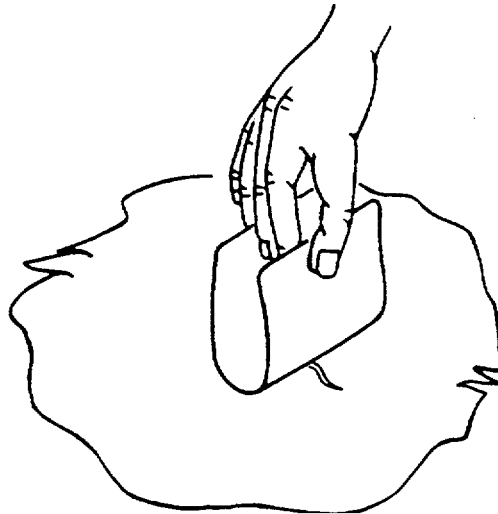

FIGURE 3-3. APPLYING PATCH

- q. Smooth down patch with edge of hand, one end at a time, so as to avoid any air bubbles.
- r. Use a roller, or equivalent, to firmly roll down the entire patch, from center of patch out toward edges to prevent formation of air bubbles.

s. If a second patch is being applied, proceed with step t, below; otherwise proceed to step v.

NOTE

Maximum shelf life of mixed adhesive is given in table 3-4. If second patch is to be applied, ensure that it is done within this time limit. Repair will not succeed if mixed adhesive sits too long.

t. Let first patch set for a few (approximately 2 to 3) minutes.

u. Repeat steps n through r, above, to apply second (outside) patch. Outside patch must be aligned with inside patch (outline of inside patch will be visible).

v. Allow repair to set until cured before flexing fabric or putting tank back into service. Approximate curing times are given in Table 3-5.

Table 3-5. Curing Times For Fabric Repairs.

These times are for a thickness of approximately 0.10 inches (0.25 cm); they will be reduced for thicker sections and extended for thinner sections.

Temperature	Movement Or Use Involving No Loading Or Immersion	Full Mechanical Or Thermal Loading	Immersion In Chemicals
41 F (5°C)	6 hours	72 hours	120 hours (5 days)
50°F (10°C)	4 hours	48 hours	84 hours
59°F (15°C)	3 hours	48 hours	72 hours
68°F (20°C)	2 hours	24 hours	60 hours
77°F (25°C)	1.5 hours	24 hours	48 hours
86OF (30-C)	1 hour	24 hours	36 hours

3-6. End Clamp Assembly

One end of the tank is closed by a mechanical assembly. This mechanical assembly consists of the following items:

- Handles
- Top Clamps
- Bottom Clamps
- Cap Screws
- Washers

a. Inspect

- (1) Inspect each of the top clamps (3, 5, and 13, Fig. C-1 or Fig. C-1A) for burrs, sharp edges and cracks.
- (2) Inspect each of the bottom clamps (4, 6, and 14, Fig. C-1 or Fig. C-1A) for burrs, sharp edges, cracks and damaged threads.
- (3) Check handles (10, Fig. C-1 or Fig. C-1A) for burrs, sharp edges and cracks.
- (4) Check all cap screws for proper torque of 70 ± 5 ft. lbs.

b. Repair

Repair any damage to the end clamp assembly by removing and repairing only one assembly at a time. The right and left, top and bottom end clamps and handles must remain in the original location.

c. Replacement of individual Clamp Assembly (Fig. C-1 or Fig. C-1A)

- (1) Remove the cap screw (12) and flat washer (11) from the top (5) and bottom (6) clamp assembly.
- (2) Remove the assembly from the tank.
- (3) Remove all burrs and sharp edges from the clamps.
- (4) If the clamps are cracked or the bottom clamp threads are damaged, replace.
- (5) Place the top (3, 5 and 13) and bottom (4, 6 and 14) clamps on the tank.
- (6) Place the $\frac{1}{2}$ -13 (12) hex head cap screw thru the flat washer (11), top clamps (3, 5 and 13) and thread it into the bottom clamps (4, 6 and 14).
- (7) Torque to 70 ± 5 ft. lbs.

d. Replace Handle Grip Assemblies (Fig. C-1 or Fig. C-1A)

- (1) Remove the three cap screws (12) and flat washers (11) from the handle assemblies. The handle assembly consists of one handle (10) and three bottom clamps (6).
- (2) Remove the handle (10) and bottom clamps (6) from the tank.
- (3) Remove all burrs and sharp edges from the handle and clamps.
- (4) If the handle is cracked or the bottom clamp is cracked or contains damaged threads, replace.

- (5) Place the handle (10) on the top of the tank and align the three (3) holes in the tank.
 - (6) Assemble one bottom clamp (6) and washer (11) at a time by inserting the ½-13 hex head cap screw (12) thru the washer (11) and thru the hole in the handle and thread it into the bottom clamp (6). Hand tighten bolt only.
 - (7) Assemble the remaining two bottom clamps (6) as described in step 3-6, d 6.
- (8) Torque all three cap screws to 70 ± 5 ft. lbs.

3.7. Filler/Discharge Assembly

a. Adaptor - 4" (9) (Fig. C-2)

- (1) Remove the adaptor (9) from the gate valve (5).
- (2) Clean the adaptor using a mild soap and water solution with a stiff bristle brush, remove any foreign matter.
- (3) Clean all sealing surfaces and threads.
- (4) Inspect for cracks, dents, breaks or wear. Replace if unserviceable.

b. Pressure Gage (7)

- (1) Remove the pressure gage (7) from the gate valve(s) flow tube.
- (2) Check the gage by blowing on the connecting nipple. Average lung pressure will show 2-2½ PSI reading on the gage.
- (3) Inspect for bent indicator or broken face plate. Replace if necessary.

c. Gate Valve - 4" (5) (Fig. C-2)

- (1) Remove the gate valve from the tank by removing the four bolts (12 Fig. C-1 or Fig. C-1A) from the top and bottom pipe clamps (1 and 2, Fig. C-2).
- (2) Remove the adjacent top and bottom clamps (5 and 6, Fig. C-1 or Fig. C-1A) if necessary.
- (3) Remove the valve from the tank.
- (4) Remove the inside flange (3, Fig. C-2) from the gate valve tube.
- (5) Remove the two rubber adaptors.
- (6) Clean all parts using a mild soap and water solution with a stiff bristle brush. Remove any foreign matter from the parts.
- (7) Inspect all parts for cracks, dents, breaks or wear. Replace if unserviceable.
- (8) Reassemble in reverse order of disassembly.

NOTE: Moisten inside of rubber adapter (4, Fig. C-2) for ease of assembly.

■ 3-8. Tie Down Assembly (2, Fig. C-1 or Fig. C-1A)

a. Ratchet Assembly

- (1) Remove the ratchet take-up mechanism from the anchor points on the trailer.
- (2) Clean all parts, using a mild soap and water with a stiff bristle brush. Remove any foreign matter from the parts.
- (3) Inspect for cracks, dents, breaks, jammed mechanism, missing spring and wear. Replace if necessary.

b. Belts

- (1) Check the belts for abrasion, tears and wear. Replace if necessary.

c. Semi-trailer Anchor Points

- (1) Check all anchor points for broken, bent or distorted eye bolts. Replace if necessary.

3-9. Cleaning of Tank (Temporary and Long Term Storage)

The tank is easily cleaned after normal usage.

With the tank empty and flat on the truck, partially fill it with 100 to 300 gallons of clean disinfectant and water solution. The solution consists of 1/2 gallon of commercial bleach mixed in 250 gallons of fresh water. Surge the cleansing solution by walking back and forth on the tank or by rocking the truck with abrupt starts and stops. The resultant surge will clean or rinse the collapsed tank without exposing its interior to contaminants or foreign objects. Flush tank with 250 gallons of fresh water, surge as above and drain.

When the cleaning is complete, close the tank valve immediately to hermetically seal out contaminants.

3-10. Hydrostatic Testing Procedure

WARNING

DO NOT AIR TEST TANK. OVER-PRESSURIZATION
COULD CAUSE TANK TO BURST, RESULTING IN
DEATH OR SERIOUS INJURY TO PERSONNEL.

a. Equipment

- (1) Water supply 100 GPM
- (2) Smooth area for testing and draining water.

- (3) Water hose, at least 2" ID and 50' long to facilitate rapid filling and draining.
 - (4) Two gages, 30 PSI capacity (gage should be checked periodically).
 - (5) Gage hose with ¼" ID x 50' long to connect both gages with petcock at tank flow tube.
- b. For tank containers 7' 4" flat width, the test pressure is:
 - (1) Initial pressure - 4 PSI and torque bolts to 70 ft. lbs.
 - (2) Test, Stand 7 PSI for 2 hours
 - (3) Maximum pressure - 12 PSI
 - (4) Rise to maximum - 10 min. from 7 to 12 PSI
 - c. Place tank in test area, making certain that all the air has been expelled by flattening the tank completely with the air relief valve open. Close air relief valve before beginning test:
 - d. Bleed air off filling line to prevent air from entering tank. Attach supply hose securely. Then attached ¼" hose to petcock on flow tube. Close petcock, turn on water.
 - e. After tank is partially full, approximately two feet high, open petcock on flow tube and bleed air off ¼" hose and attach both gages. Open petcock and fill.
 - f. When the water pressure in the tank reaches 4 PSI, shut off water supply. Retorque all screws to recommended torque. Proceed watching gages carefully. At 7 PSI immediately shut off water supply and allow tank to stand for 2 hours. This is to allow the tank to stretch and adjust to higher pressure.

After the two-hour period open supply valve and proceed, throttling down supply valve so that there will be approximately a 10 minute rise from 7 PSI to 12 PSI.
 - g. When test goes beyond 7 PSI, all personnel should be kept at a minimum of 50 feet away from tank. A failure at high pressure could cause injury.
 - h. Immediately upon reading 12 PSI, close the supply valve and open the drain valve. Do not let the tank stand at 12 PSI for any length of time as this may overstress the internal cord structure.
 - i. Drain tank completely. Remove hose; then, if necessary, dry.
 - j. After the hydrostatic test is completed, retorque all screws and return tank to service.

3-11. Pressure Relief Valve (15) (Figure C-1 or Figure C-1A)

a. Valve Nut

(1) Tighten to 30 +/- ft.lbs.

b. Plug

(1) Tighten plug finger tight.

APPENDIX A

REFERENCES

- A-1. Destruction of Army Material
- TM 750-244-3 Procedures for Destruction of Equipment to Prevent Enemy Use
- A-2. Shipment and Storage
- TM 38-230 Preservation: Packaging and Packing of Military Supplies and Equipment
- TM 5-700 Storage, Inspection and Preservation of Potable Water Equipment
- A-3. Maintenance Forms and Records
- DA PAMPHLET Maintenance Forms and Records. The Army
738-750 Maintenance Management Systems (TAMMS)
- A-4. Maintenance of Supplies and Equipment
- TB 750-25 Maintenance of Supplies and Equipment, Army Test Measures and Diagnostic Equipment (TMDE Calibration and Repair Support Program)

APPENDIX B

MAINTENANCE ALLOCATION CHART

Section I. General

B-1. General

- a. This section provides a general explanation of all maintenance and repair functions authorized at various maintenance levels.
- b. Section II designates overall responsibility for the performance of maintenance functions on the identified end item or component and the work measurement time required to perform the functions by the designated maintenance level. The implementation of the maintenance functions upon the end item or component will be consistent with the assigned maintenance functions.
- c. Section III lists the tools and test equipment required for each maintenance function as referenced from Section II. (Not applicable).

B-2. Explanation of Columns in Section II

- a. Column (1), Group Number. Column (1) lists group numbers to identify related components, assemblies, subassemblies and modules with the next higher assembly. The applicable groups are listed in the MAC in disassembly sequence beginning with the first group remove.
- b. Column (2), Component/Assembly. This column contains the noun name of components, assemblies, subassemblies and modules for which maintenance is authorized.
- c. Column (3), Maintenance Functions. This column lists the functions to be performed on the item listed in Column (2). The maintenance functions are defined as follows:
 - (1) Inspect. To determine serviceability of an item by comparing its physical, mechanical and/or electrical characteristics with established standards through examination.
 - (2) Test. To verify serviceability and detect incipient failure by measuring the mechanical or electrical characteristics of an item and comparing those characteristics with prescribed standards.
 - (3) Service. Operations required periodically to keep an item in proper operation condition, i.e., to clean (decontaminated), to preserve, to drain, to paint or to replenish fuel, lubricants, hydraulic fluids or compressed air supplies.

- (4) Adjust. To maintain within prescribed limits, by bringing into proper or exact position, or by setting the operating characteristics to specified parameters.
 - (5) Align. To adjust specified variable elements of an item to bring about optimum or desired performance.
 - (6) Calibrate. To determine and cause corrections to be made or to be adjusted on instruments or test measuring and diagnostic equipments used in precision measurement. Consists of comparison of two instruments, one of which is a certified standard of known accuracy, to detect and adjust any discrepancy in the accuracy of the instrument being compared.
 - (7) Install. The act of emplacing, seating, or fixing into position an item, part of module (component or assembly) in a manner to allow the proper functioning of an equipment or system.
 - (8) Replace. The act of substituting a serviceable like type part, sub-assembly, or module (component or assembly) for an unserviceable counterpart.
 - (9) Repair. The application of maintenance services (inspect, test, service, adjust, calibrate or replace) or other maintenance actions (welding, grinding, riveting, straightening, facing, remachining or resurfacing) to restore serviceability to an item by correcting specific damage, fault, malfunction or failure in a part, sub-assembly, module (component or assembly), end item or system.
 - (10) Overhaul. That maintenance effort (service/action) necessary to restore an item to a completely serviceable/operational condition as prescribed by maintenance standards (i.e., DMWR) in appropriate technical publications. Overhaul is normally the highest degree of maintenance performed by the Army. Overhaul does not normally return an item to a like new condition.
 - (11) Rebuild. Consists of those services/actions necessary for the restoration of unserviceable equipment to a like new condition in accordance with original manufacturing standards. Rebuild is the highest degree of material maintenance applied to Army equipment. The rebuild operation includes the act of returning to zero those age measurements (hours/miles, etc.) considered in classifying Army equipment/components.
- d. Column (4), Maintenance Category. This column is made up of sub-columns for each category of maintenance. Work time figures are listed in these sub-columns for the lowest level of maintenance authorized to perform the function listed in Column (3). These figures indicate the average active time required to perform the maintenance function at the indicated category of maintenance under typical field operating conditions:

- C - Operator or crew
- O - Organization maintenance
- F - Direct support maintenance
- H - General support maintenance
- D - Depot maintenance

e. Column (5), Tools and Equipment. This column is provided for referencing by code, the common tools sets (not individual tools) special tools, test and support equipment required to perform the designated function.

Section II. Maintenance Allocation Chart

(1) Group Number	(2) Component Assembly	(3) Maintenance Function	(4)* Maintenance Category					(5) Tools and Equipment
			C	O	F	H	D	
01	HOSE ASSEMBLY	Inspect	0.2					
		Replace	0.2					
02	FILLER/DISCHARGE ASSEMBLY	Inspect	0.2					
		Replace	0.2					
		Repair	0.5					
03	EMERGENCY REPAIR ITEMS	Inspect	0.2					
		Install	1.0					
		Replace	0.2					
04	GAGE	Inspect	0.1					
		Replace	0.1					
05	TANK	Inspect	0.3					
		Repair	0.3					
		Replace	0.3					
06	TIE-DOWN KIT ASSEMBLY	Inspect	0.1					
		Replace	0.2					

* Subcolumns are as follows: C - Operator Crew; O - Organizational;
F - Direct Support; H - General Support;
D - Depot

APPENDIX C
COMPONENT IDENTIFICATION LIST

Section I. INTRODUCTION

C-1. Scope

This appendix lists and identifies components of the 3,000 gallon potable water (drinking water) tank.

Section II. Component Identification List

MANUFACTURER		MODEL NO.		USABLE ON CODE	
Uniroyal Amfuel		3, 000 gallon 91093		EZS FGK	

Illustration (a) Figure No.	(b) Item No.	Part Number	CAGEC	DESCRIPTION Usable on Code	NSN	U/M	QTY INC. IN UNIT
			05476	TANK ASSEMBLY (EZS)			
		91093	05476	TANK, ASSEMBLY (FGK)			
C-1	1		05476	TANK, COLLAPSIBLE (EZS)		EA	1
C-1A	1	RE-231	05476	TANK COLLAPSIBLE (FGK)		EA	1
C-1	2	5332.0539	05476	TIE-DOWN (EZS)		EA	1
C-1A	2	FCD64632	05476	TIE-DOWN ASSEMBLY (FGK)		EA	4
C-1	3	5332.0546	05476	TOP END CLAMP, LEFT HAND (EZS)		EA	2
C-1A	3	HC-439-1	05476	TOP END CLAMP, LEFT HAND (FGK)		EA	2
C-1	4	5332.0547	05476	BOTTOM END CLAMP, LEFT HAND (EZS)		EA	2
C-1A	4	HC-440-2	05476	BOTTOM END CLAMP, LEFT HAND (FGK)		EA	2
C-1	5	5332.0198	05476	TOP CLAMP (EZS)		EA	27
C-1A	5	HC-270-3	05476	TOP CLAMP (FGK)		EA	27
C-1	6	5332.6495	05476	BOTTOM CLAMP (EZS)		EA	33
C-1A	6	HC-270-2	05476	BOTTOM CLAMP (FGK)		EA	33
C-1	10	5332.0312	05476	HAND GRIP (EZS)		EA	2

Illustration (a) Figure No.	(b) Item No.	Part Number	CAGEC	DESCRIPTION Usable on Code	NSN	U/M	QTY INC. IN UNIT
C-1A	10	HC-273-3	05476	HAND GRIP (FGK)		EA	2
C-1	11	5332.0560	05476	FLAT WASHER, 1/2" (EZS)		EA	41
C-1A	11	AN960KD1016	08928	FLAT WASHER, 1/2" (FGK)		EA	41
C-1	12	MS16208-141	96906	CAP SCREWS, HEX HD 1-2/13 x 2-1/2 (EZS)	5306-00-469-5339	EA	41
C-1A	12	MS16208-141	96906	CAP SCREWS, HEX HD 1-2/13 x 2-1/2 (FGK)	5306-00-469-5339	EA	41
C-1	13	5332.0548 (EZS)	05476	TOP END CLAMP, RIGHT HAND		EA	2
C-1A	13	HC-440-1	05476	TOP END CLAMP, RIGHT HAND (FGK)		EA	2
C-1	14	5332.0550	05476	BOTTOM END CLAMP, RIGHT HAND (EZS)		EA	2
C-1A	14	HC-439-2	05476	BOTTOM END CLAMP, RIGHT HAND (FGK)		EA	2
C-1	1	55332.1141	05476	RELIEF VALVE (EZS)		EA	1
C-1A	15	P-800	17673	RELIEF VALVE (FGK)		EA	1
C-1A	16	90082	05476	BED CLOTH (FGK)		EA	1
C-2	1	5332.6521	05476	FILLER/DISCHARGE ASSEMBLY 4" PIPE CLAMP, BOTTOM (EZS)		EA	1
		HC-274-2	05476	4" PIPE CLAMP, BOTTOM (FGK)		EA	1
C-2	2	5332.0311	05476	4" PIPE CLAMP, TOP (EZS)		EA	1
		HC-274-3	05476	4" PIPE CLAMP, TOP (FGK)		EA	1
C-2	3	5332.3172	05476	4" INSIDE FLANGE (EZS)		EA	1
		HB-187	05476	4" INSIDE FLANGE (FGK)		EA	1
C-2	4	5332.6011	05476	4" ADAPTER (EZS)		EA	2
		RD-1 07-2	05476	4" ADAPTER (FGK)		EA	2
C-2	5	5332.0552	05476	4" GATE VALVE (EZS)		EA	1
		HD-545-8	05476	4" GATE VALVE (FGK)		EA	1

Change 5

C-2

Illustration (a) Figure No.	(b) Item No.	Part Number	CAGEC	DESCRIPTION Usable on Code	NSN	U/M	QTY INC. IN UNIT	
C-2	6	5332.1267	05476	AIR COCK (EZS)		EA	1	█
		4793K52	39428	AIR COCK (FGK)	4820-01-306-3076	EA	1	█
C-2	7	5332.1269	05476	PRESSURE GAGE (EZS)		EA	1	█
		4089K33	39428	PRESSURE GAGE (FGK)	6685-01-360-1874	EA	1	█
C-2	8	5332.1268	05476	ELBOW, 1/4" x 90 DEGREE (EZS)		EA	1	█
		MS51952-2	96906	ELBOW, 1/4" x 90 DEGREE (FGK)	4730-00-277-5553	EA	1	█
C-2	9	MS27022-17	96906	4" ADAPTER, FEMALE NPT (EZS)	4730-00-840-0797	EA	1	█
		MS27020-17	96906	4" ADAPTER, FEMALE NPT (FGK)	4730-00-840-0796	EA	1	█
C-3	1	5332.1270	05476	HOSE ASSEMBLY (EZS)		EA	2	█
		FCC-63955	05476	HOSE ASSEMBLY (FGK)		EA	2	
				TIE-DOWN ASSEMBLY (M-127 TRAILER)				
2-4	1	5332.0539	05476	BELT, 2" x 33', BEIGE (EZS)		EA	4	█
		FCD64632-1	05476	BELT, 2" x 33', BEIGE (FGK)		EA	4	
2-4	2	5332.0907	05476	SHACKLE, 5/8" (EZS)		EA	8	█
		FCD64632-3	05476	SHACKLE, 5/8" (FGK)	5340-00-720-8864	EA	8	█
2-4	3	5332.0539	05476	RATCHET TAKE-UP ASSEMBLY (EZS)		EA	8	█
		FCD64632-2	05476	RATCHET TAKE-UP ASSEMBLY (FGK)		EA	8	
2-3	1	5332.7078	05476	HEX NUT, 5/8" (EZS)		EA	8	█
2-3	2	5332.7088	05476	LOCKWASHER, 5/8" (EZS)		EA	8	█
		FCD64632-6	05476	LOCKWASHER, 5/8" (FGK)		EA	8	
2-3	3	5332.7078	05476	WASHER, FLAT, 5/8" (EZS)		EA	8	█
		FCD64632-5	05476	WASHER, FLAT, 5/8" (FGK)		EA	8	
2-3	4	5332.0511	05476	RETAINER PLATE (EZS)		EA	16	█

Illustration (a) Figure No.	(b) Item No.	Part Number	CAGEC	DESCRIPTION Usable on Code	NSN	U/M	QTY INC. IN UNIT
		FCD64632-4	05476	POCKET PLATE (FGK)		EA	16
2-3	5	5332.7089	05476	EYEBOLT, 5/8" (EZS)		EA	8
		FCD64632-7	05476	EYEBOLT WITH HEX NUT, 5/8" (FGK)		EA	8
				TIE-DOWN ASSEMBLY (M-871 TRAILER)			
2-5	1	5332.0539	05476	BELT, 2" x 33', BEIGE (EZS)		EA	4
		FCD64632-1	05476	BELT, 2" x 33', BEIGE (FGK)		EA	4
2-5	2	5332.0907	05476	SHACKLE, 5/8" (EZS)		EA	8
		FCD64632-3	05476	SHACKLE, 5/8" (FGK)	5340-00-720-8864	EA	8
2-5	3	5332.0539	05476	RATCHET TAKE-UP ASSEMBLY (EZS)		EA	8
		FCD64632-2	05476	RATCHET TAKE-UP ASSEMBLY (FGK)		EA	8
2-2	1	5332.7078	05476	HEX NUT, 5/8" (EZS)		EA	8
2-2	2	5332.7088	05476	LOCKWASHER, 5/8" (EZS)		EA	8
		FCD64632-6	05476	LOCKWASHER, 5/8" (FGK)		EA	8
2-2	3	5332.7078	05476	WASHER, FLAT, 5/8" (EZS)		EA	8
		FCD64632-5	05476	WASHER, FLAT, 5/8" (FGK)		EA	8
2-2	4	5332.0499	05476	RETAINER PLATE, BOTTOM (EZS)		EA	8
		FCD64632-8	05476	RETAINER PLATE, BOTTOM (FGK)		EA	8
2-2	5	5332.7089	05476	EYEBOLT, 5/8" (EZS)		EA	8
		FCD64632-7	05476	EYEBOLT WITH HEX NUT, 5/8" (FGK)		EA	8
2-2	6	5332.0511	05476	RETAINER PLATE, TOP (EZS)		EA	8
		FCD64632-8	05476	RETAINER PLATE, TOP (FGK)		EA	8
				TIE-DOWN ASSEMBLY (M-872 TRAILER)			
2-6	1	5332.0539	05476	BELT, 2" x 33', BEIGE (EZS)		EA	4

Illustration (a) Figure No.	(b) Item No.	Part Number	CAGEC	DESCRIPTION Usable on Code	NSN	U/M	QTY INC. IN UNIT
		FCD64632-1	05476	BELT, 2" x 33', BEIGE (FGK)		EA	4
2-6	2	5332.0907	05476	SHACKLE, 5/8" (EZS)		EA	8
		FCD64632-3	05476	SHACKLE, 5/8"5340-00-720-8664 (FGK)		EA	8
2-6	3	5332.0539	05476	RATCHET TAKE-UP ASSEMBLY (EZS)		EA	8
		FCD64632-2	05476	RATCHET TAKE-UP ASSEMBLY (FGK)		EA	8
2-2	1	5332.7078	05476	HEX NUT, 5/8" (EZS)		EA	8
2-2	2	5332.7088	05476	LOCKWASHER, 5/8" (EZS)		EA	8
		FCD64632-6	05476	LOCKWASHER, 5/8" (FGK)		EA	8
2-2	3	5332.7078	05476	WASHER, FLAT, 5/8" (EZS)		EA	8
		FCD64632-5	05476	WASHER, FLAT, 5/8" (FGK)		EA	8
2-2	4	5332.0499	05476	RETAINER PLATE, BOTTOM (EZS)		EA	8
		FCD64632-8	05476	RETAINER PLATE, BOTTOM (FGK)		EA	8
2-2	5	5332.7089	05476	EYEBOLT, 5/8" (EZS)		EA	8
		FCD64632-7	05476	EYEBOLT WITH HEX NUT, 5/8" (FGK)		EA	8
2-2	6	5332.0511	05476	RETAINER PLATE, TOP (EZS)		EA	8
		FCD64632-8	05476	RETAINER PLATE, TOP (FGK)		EA	8
C-4	1	13202E2870-1	81336	REPAIR COMPONENTS CLAMP, SEALING, 3 INCH (EZS)	5340-00-720-8864	EA	4
C-4	2	13202E2870-2	81336	CLAMP, SEALING, 5 INCH (EZS)	5340-00-720-8863	EA	2
C-4	3	13202E2870-3	81336	CLAMP, SEALING, 7 INCH (EZS)	5340-00-720-8858	EA	2
C-4	4	13211E3085	97403	PLUG, TAPERED, WOOD, 3 INCH (EZS)	5510-00-255-9493	EA	2
C-4	5	13211E3084	97403	PLUG, TAPERED, WOOD, 5 INCH (EZS)	5510-00-255-9492	EA	2
		MIL-R-52255	81349	REPAIR KIT, TYPE II (FGK)	8110-00-856-6246	EA	1

Illustration		Part Number	CAGEC	DESCRIPTION Usable on Code	NSN	U/M	QTY INC. IN UNIT
(a) Figure No.	(b) Item No.						
2-4	3	5332.0539	05476	RATCHET TAKE-UP ASSEMBLY (EZS)		EA	2
2-4	1	5332.0539	05476	BELT, 2" x 33', BEIGE (EZS)		EA	1
C-1A	2	FCD64632	05476	TIE-DOWN ASSEMBLY (FGK) ACCESSORIES		EA	2
2-1	1	FCC-64630-1	05476	SLING (EZS)		EA	1
		FCC-64630-1	05476	SLING (FGK)		EA	1
2-1	2	FCC-64630-2	05476	LIFT STRAPS (EZS)		EA	2
		FCC-64630-2	05476	LIFT STRAPS (FGK)		EA	2
2-1	3	5332.0929	05476	DUFFLE BAG (EZS)		EA	1
		FCC-64629	05476	DUFFLE BAG (FGK)		EA	1
		13225E9139-3	97403	SWIVEL, HOSE, 1-1/2" (FGK)	4730-01-109-0790	EA	1
		MS49000-17	97403	REDUCER, 4" TO 2" (FGK)	4730-01-064-0560	EA	1
		MS49002-9	05476	REDUCER, TYPE XIII (FGK)		EA	1
		13225E9135-1	05476	SUCTION HOSE, 2" x 10' WITH CAP/PLUG/CHAIN (FGK)		EA	2
		13225E39096	97403	NOZZLE, DISTRIBUTION (FGK)	4610-01-188-8198	EA	1

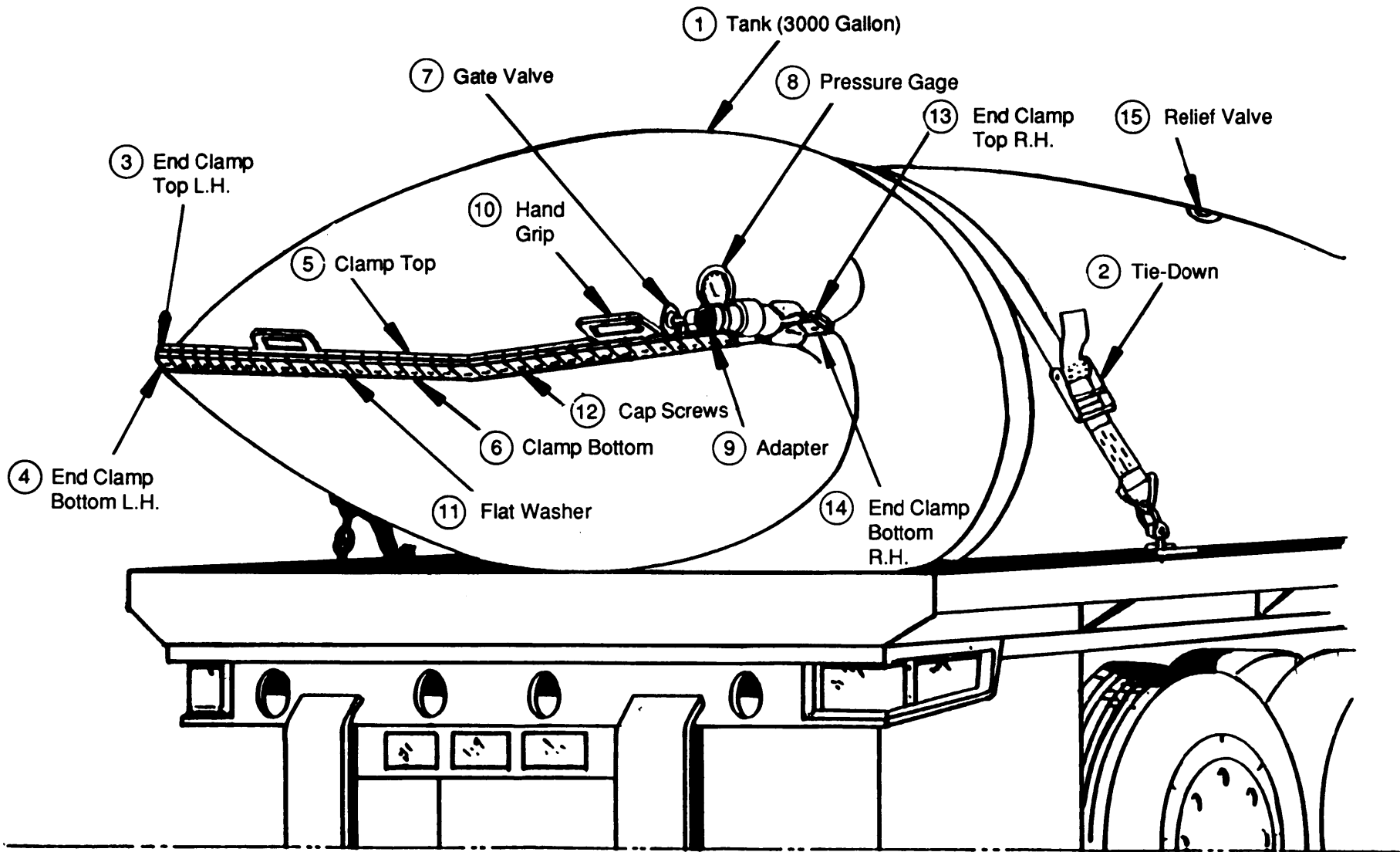

TANK WITH HARDWARE
AND TIE-DOWN ASSEMBLY (MODEL 3,000 gallon)

FIGURE C-1

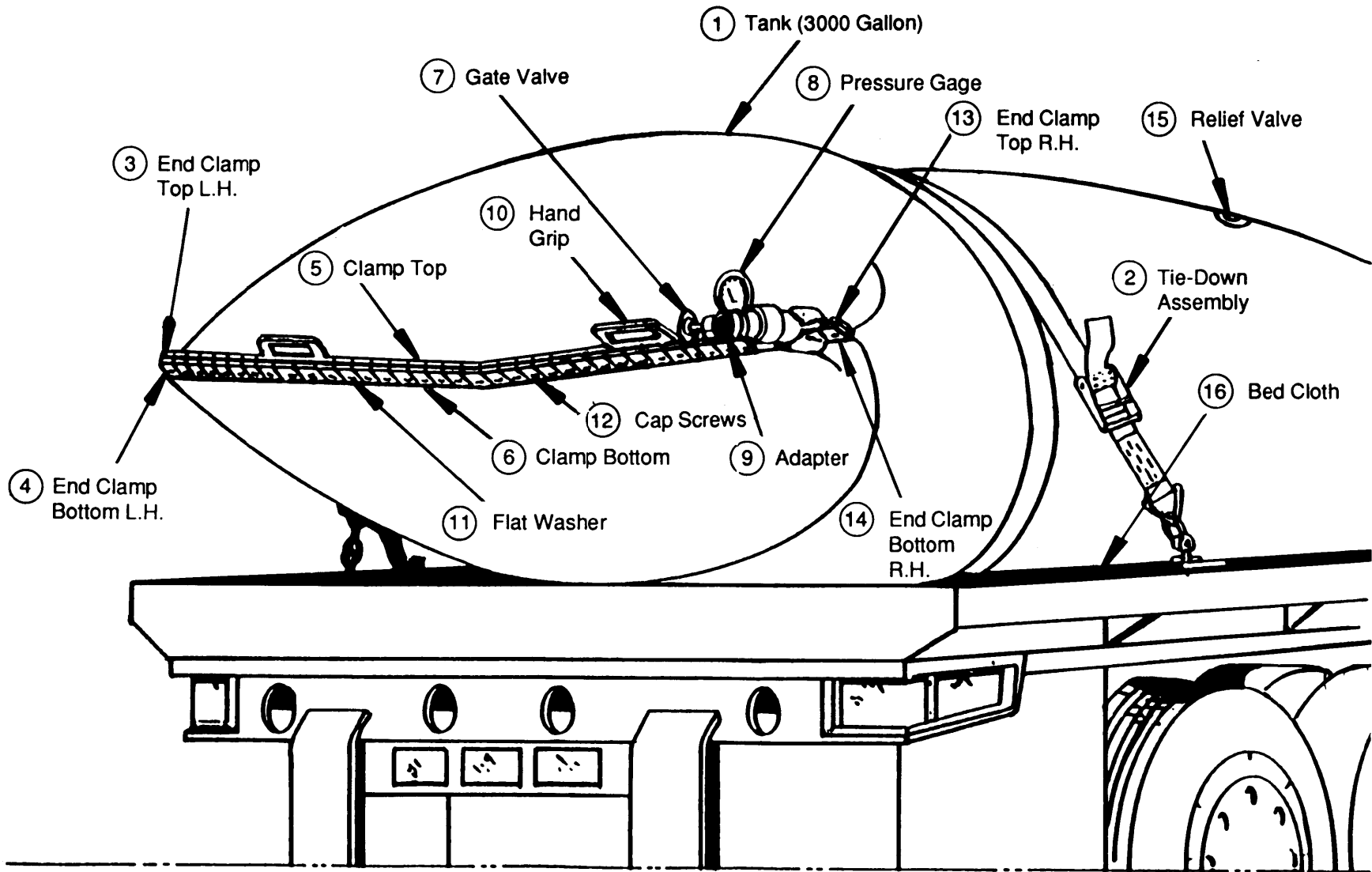

TANK WITH HARDWARE AND TIE-DOWN ASSEMBLY (Model 91093)

FIGURE C-1A

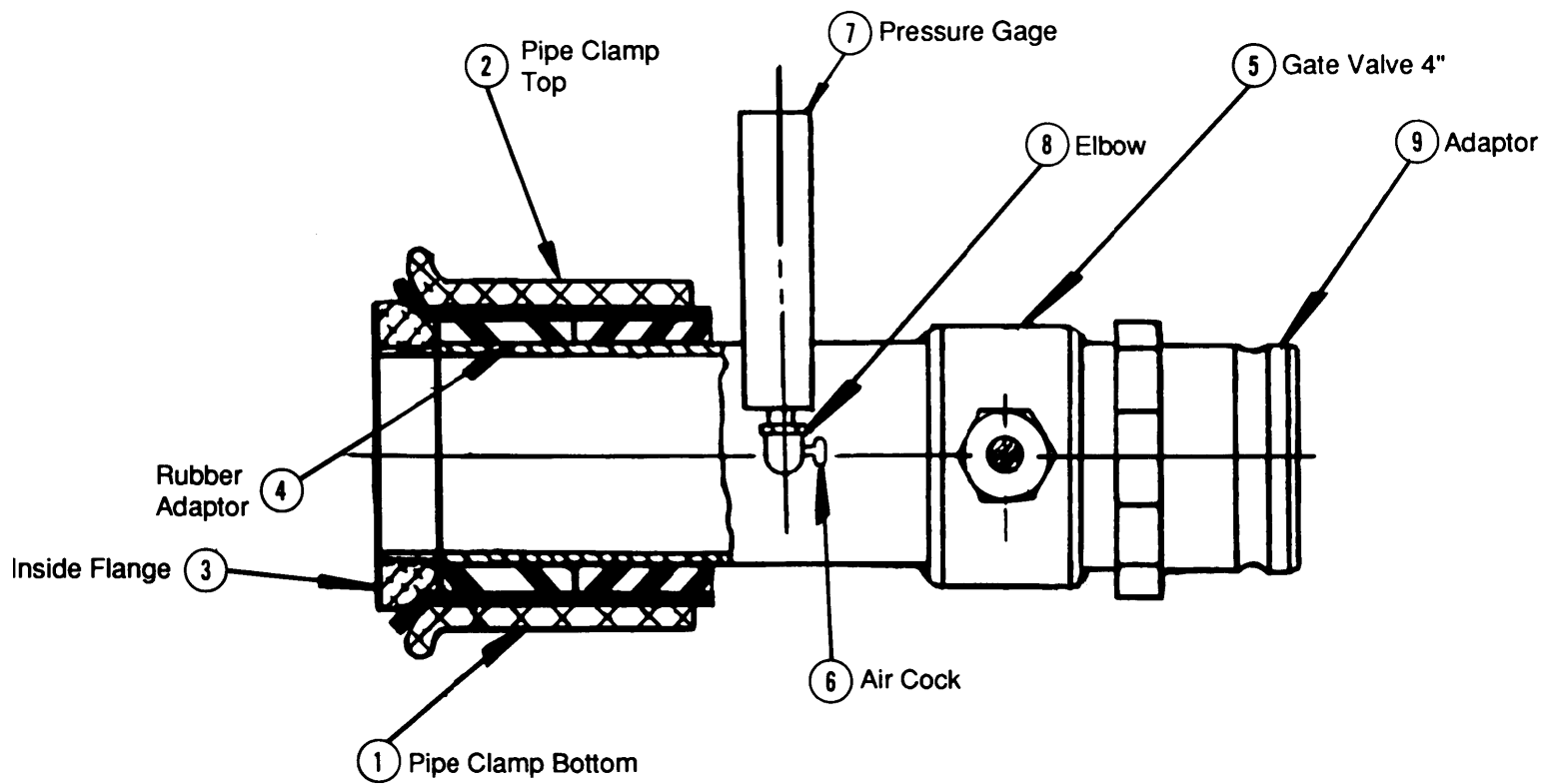

FIGURE C-2 FILLER/DISCHARGE ASSEMBLY

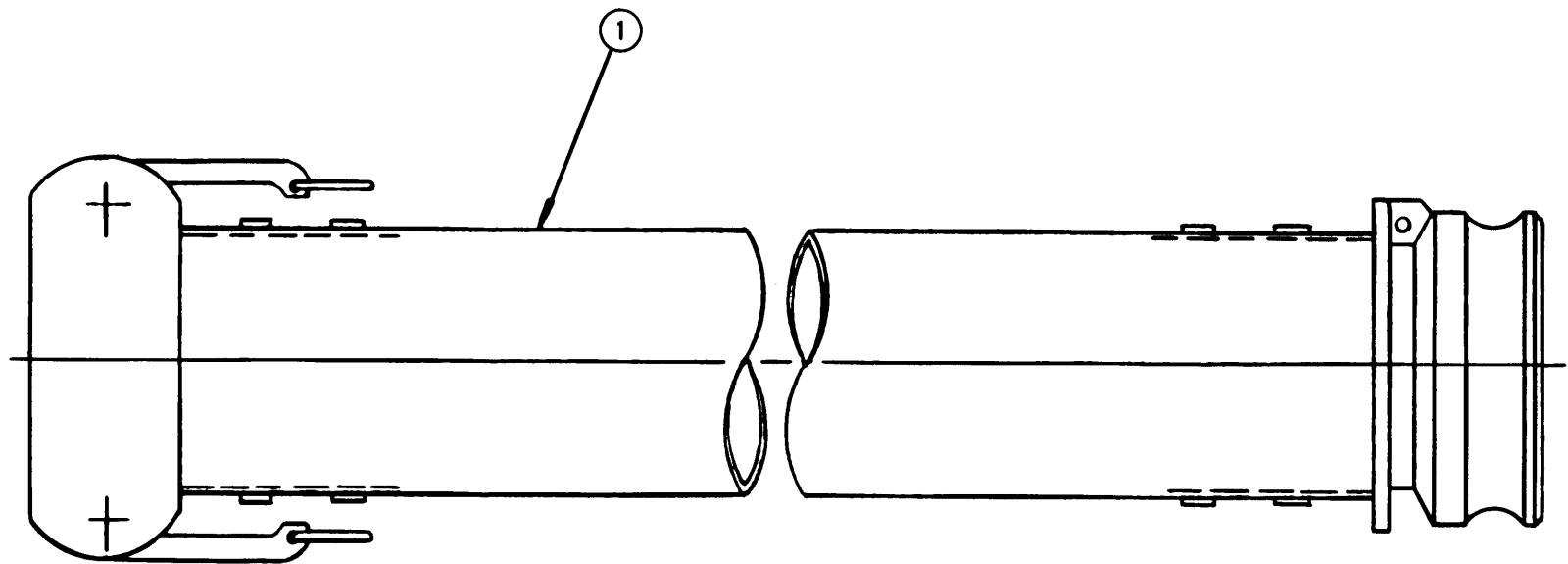

FIGURE C-3 HOSE ASSEMBLY

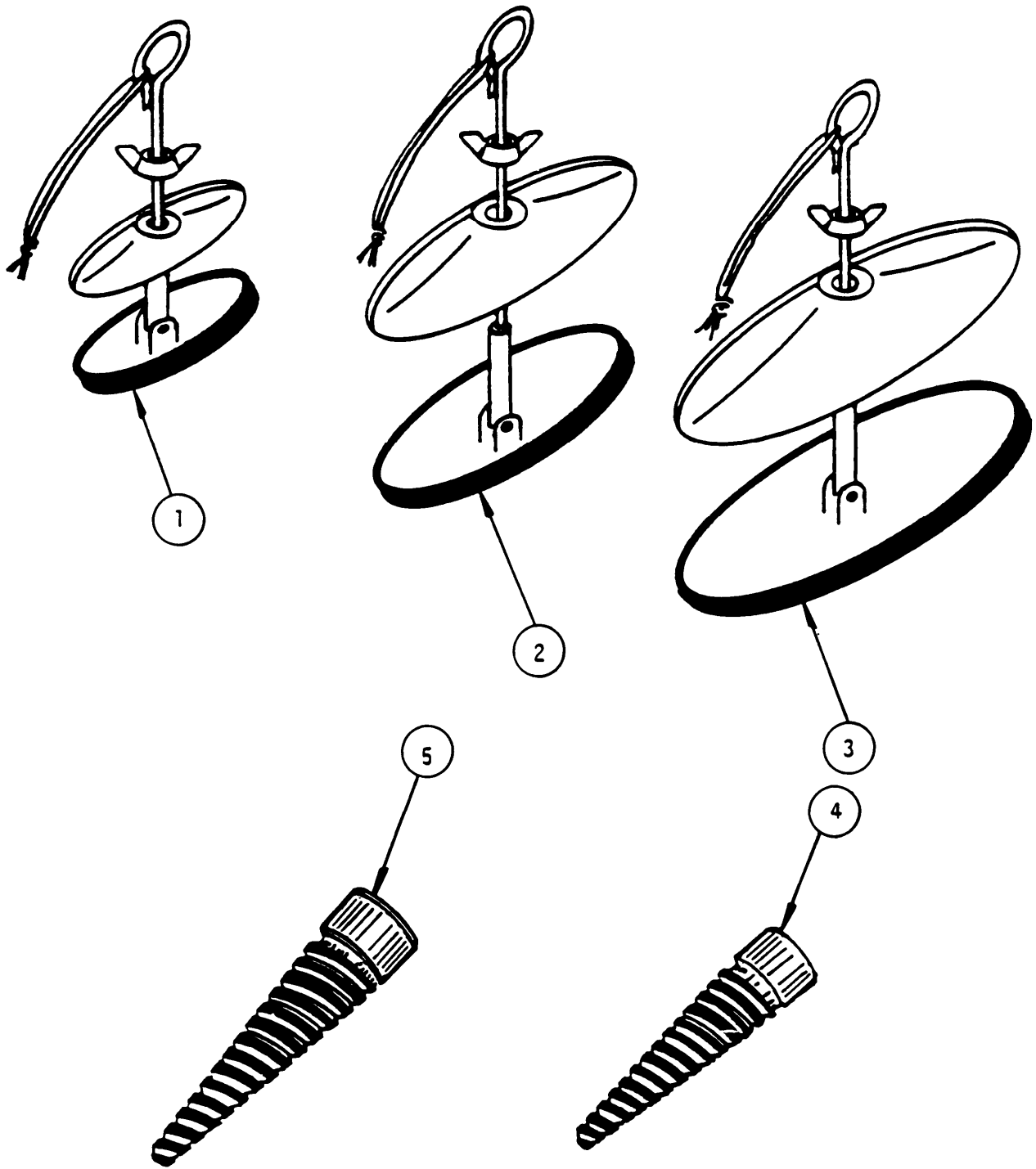

FIGURE C-4 SEALING CLAMPS AND WOOD PLUGS

**APPENDIX D
ADDITIONAL AUTHORIZATION LIST**

Section I. INTRODUCTION

1. SCOPE

This appendix lists additional items you are authorized for the support of the tank.

2. GENERAL

This list identifies items that do not have to accompany the tank and that do not have to be turned in with it. These items are all authorized to you by CTA, MTOE, TDA, or JTA.

3. EXPLANATION OF LISTING

National stock numbers, descriptions, and quantities are provided to help you identify and request the additional items you require to support this equipment. The items are listed in alphabetical sequence by item name under the type document (i.e., CTA, MTOE, TDA, or JTA) which authorizes the item(s) to you.

Section II. ADDITIONAL AUTHORIZATION LIST

(1) National Stock Number	(2) Description FSCM and Part Number Usable On Code	(3) U/M	(4) Qty Auth
	MTOE AUTHORIZED ITEMS		
4720-01-138-8986	Hose (22-H-601), 2-inch, 20-ft. length; 97403 P/N 13225E9136-2	ea	1
4720-01-140-6288	Hose 4-inch, 20-ft. length; 97403 P/N 13225E9136-4	ea	1
4730-01-064-0560	Reducer, Female to Male, Quick Disconnect; 96906 P/N MS49000-17-4"-2"	ea	1
4730-00-951-3295	Reducer, Female to Male; 96906 P/N MS4900-5-2"-11 /2"	ea	1
4730-01-109-0790	Swivel Hose; 97403 P/N 13225E9139-3	ea	1

SECTION II. ADDITIONAL AUTHORIZATION LIST

(1) NATIONAL STOCK NUMBER	(2) DESCRIPTION FSCM AND PART NUMBER USABLE ON CODE	(3) U/M	(4) QTY AUTH
MTOE AUTHORIZED ITEMS			
4610-01-188-8198	NOZZLE DISTRIBUTION, POTABLE WATER; 97403 P/N 13225E9096	EA	1
4610-01-163-4684	SUCTION HOSE, 2-INCH, 20 FT. LENGTH; 97403 P/N 13225E9135-2	EA	1

APPENDIX E

EXPENDABLE/DURABLE SUPPLIES AND MATERIALS LIST

Section I. Introduction

E-1. Scope

This appendix lists expendable/durable supplies and materials you will need to operate and maintain the 3K water tank. These items are authorized to you by CTA 50-970, Expendable/Durable Items (except Medical, Class V, Repair Parts and Heraldic Items), or CTA 8-100, Army Medical Department Expendable/Durable Items.

E-2. Explanation of Columns

- a. Column 1 Item Number. This number is assigned to the entry in the listing and is referenced in the narrative instructions to identify the material (e.g., "Use wiping rag, Item 12, Appendix E").
- b. Column 2 Level. This column identified the lowest level of maintenance that required the listed item:
 - C Operator/Crew
 - O Unit Maintenance
- c. Column 3 National Stock Number. This is the national stock number assigned to the item; use it to request or requisition the items.
- d. Column 4 Description. Indicates the federal item name and, if required, a description to identify the item. The last line for each item indicates the part number followed by the Commercial And Government Entity (CAGE) code in parentheses, if applicable.
- e. Column 5 Unit of Measure (U/M). Indicates the measure used in performing the actual maintenance function. This measure is expressed by a two character alphabetical abbreviation (e.g., ea, in, pr). If the unit of measure differs from the rest of the issue, requisition the lowest unit of issue that will satisfy your requirements.

Section II. Expendable/Durable Supplies And Materials List

(1) Item Number	(2) Level	(3) National Stock Number	(4) Item Name Description CAGEC and Part Number	(5) U/M
1	C	5430-01-359-1078	Repair Kit, Collapsible Fabric Tank And Drums (ROCTAD), components listed in Table 3-3 (OF6E1)BOV-USA-1	EA
2	C	5120-00-243-9402	Roller, Hand	EA

*U.S. GOVERNMENT PRINTING OFFICE: 1997 - 554-024/60093

By Order of the Secretary of the Army:

Official:

R. L. DILWORTH
Brigadier General, United States Army
The Adjutant General

JOHN A. WICKHAM, JR.
General, United States Army
Chief of Staff

DISTRIBUTION:

To be distributed in accordance with DA Form 12-25A, Operator and Organizational Maintenance requirements Tank, Fabric, Collapsible, POL, 50,000, 10,000, 3,000 GAL.

RECOMMENDED CHANGES TO EQUIPMENT TECHNICAL PUBLICATIONS



THEN... JOT DOWN THE DOPE ABOUT IT ON THIS FORM. CAREFULLY TEAR IT OUT. FOLD IT AND DROP IT IN THE MAIL!

SOMETHING WRONG WITH THIS PUBLICATION?

FROM: (PRINT YOUR UNIT'S COMPLETE ADDRESS)

PFC JOHN DOE
COA, 3d ENGINEER BN
FT. LEONARDWOOD, MD 63108

DATE SENT

PUBLICATION NUMBER

TM 5-5430-213-13&P

PUBLICATION DATE

27 Oct 86

PUBLICATION TITLE

Tank, 3,000 Gallon Fabric

BE EXACT PIN-POINT WHERE IT IS

PAGE NO	PARA-GRAPH	FIGURE NO	TABLE NO
---------	------------	-----------	----------

6

2-1
a

B1

4-3

125

line 20

IN THIS SPACE TELL WHAT IS WRONG AND WHAT SHOULD BE DONE ABOUT IT:

In line 6 of paragraph 2-1a the manual states the engine has 6 Cylinders. The engine on my set only has 4 Cylinders. Change the manual to show 4 Cylinders.

Callout 16 on figure 4-3 is pointing at a bolt. In key to figure 4-3, item 16 is called a shim - Please correct one or the other.

I ordered a gasket, item 19 on figure B-16 by NSN 2 910-00-762-3001. I got a gasket but it doesn't fit. Supply says I got what I ordered, so the NSN is wrong. Please give me a good NSN

PRINTED NAME, GRADE OR TITLE AND TELEPHONE NUMBER

JOHN DOE, PFC (268) 317-7111

SIGN HERE

JOHN DOE

DA FORM 2028-2
1 JUL 79

PREVIOUS EDITIONS ARE OBSOLETE.
DRSTS-M Overprint 1, 1 Nov 80

PS--IF YOUR OUTFIT WANTS TO KNOW ABOUT YOUR RECOMMENDATION MAKE A CARBON COPY OF THIS AND GIVE IT TO YOUR HEADQUARTERS

TEAR ALONG PERFORATED LINE

FILL IN YOUR
UNIT'S ADDRESS

FOLD BACK

DEPARTMENT OF THE ARMY

OFFICIAL BUSINESS
PENALTY FOR PRIVATE USE \$300

POSTAGE AND FEES PAID
DEPARTMENT OF THE ARMY
DOD 314



TEAR ALONG PERFORATED LINE

COMMANDER
U S ARMY TROOP SUPPORT COMMAND
ATTN: AMSTR-MCTS
4300 GOODFELLOW BOULEVARD
ST. LOUIS, MO 63120-1798

FILL IN YOUR
UNIT'S ADDRESS



FOLD BACK

DEPARTMENT OF THE ARMY

OFFICIAL BUSINESS
PENALTY FOR PRIVATE USE \$300

POSTAGE AND FEES PAID
DEPARTMENT OF THE ARMY
DOD 314



TEAR ALONG PERFORATED LINE

COMMANDER
U S ARMY TROOP SUPPORT COMMAND
ATTN: AMSTR-MCTS
4300 GOODFELLOW BOULEVARD
ST. LOUIS, MO 63120-1798

FILL IN YOUR
UNIT'S ADDRESS



FOLD BACK

DEPARTMENT OF THE ARMY

OFFICIAL BUSINESS
PENALTY FOR PRIVATE USE \$300

POSTAGE AND FEES PAID
DEPARTMENT OF THE ARMY
DOD 314



TEAR ALONG PERFORATED LINE

COMMANDER
U S ARMY TROOP SUPPORT COMMAND
ATTN: AMSTR-MCTS
4300 GOODFELLOW BOULEVARD
ST. LOUIS, MO 63120-1798

RECOMMENDED CHANGES TO EQUIPMENT TECHNICAL PUBLICATIONS



THEN... JOT DOWN THE DOPE ABOUT IT ON THIS FORM. CAREFULLY TEAR IT OUT. FOLD IT AND DROP IT IN THE MAIL!

SOMETHING WRONG WITH THIS PUBLICATION?

FROM: (PRINT YOUR UNIT'S COMPLETE ADDRESS)

DATE SENT

PUBLICATION NUMBER

TM 5-5430-213-13&P

PUBLICATION DATE

27 Oct 86

PUBLICATION TITLE

Tank, 3,000 Gallon

BE EXACT. PIN-POINT WHERE IT IS

PAGE NO	PARA-GRAPH	FIGURE NO	TABLE NO
---------	------------	-----------	----------

IN THIS SPACE TELL WHAT IS WRONG AND WHAT SHOULD BE DONE ABOUT IT:

TEAR ALONG PERFORATED LINE

PRINTED NAME, GRADE OR TITLE AND TELEPHONE NUMBER

SIGN HERE

DA FORM 2028-2
1 JUL 79

PREVIOUS EDITIONS ARE OBSOLETE.
DRSTS-M Overprint 2, 1 Nov 80.

P S --IF YOUR OUTFIT WANTS TO KNOW ABOUT YOUR RECOMMENDATION MAKE A CARBON COPY OF THIS AND GIVE IT TO YOUR HEADQUARTERS.

FILL IN YOUR
UNIT'S ADDRESS



FOLD BACK

DEPARTMENT OF THE ARMY

OFFICIAL BUSINESS
PENALTY FOR PRIVATE USE \$300

POSTAGE AND FEES PAID
DEPARTMENT OF THE ARMY
DOD 314



TEAR ALONG PERFORATED LINE

COMMANDER
U S ARMY TROOP SUPPORT COMMAND
ATTN: AMSTR-MCTS
4300 GOODFELLOW BOULEVARD
ST. LOUIS, MO 63120-1798

The Metric System and Equivalents

Linear Measure

1 centimeter = 10 millimeters = .39 inch
 1 decimeter = 10 centimeters = 3.94 inches
 1 meter = 10 decimeters = 39.37 inches
 1 dekameter = 10 meters = 32.8 feet
 1 hectometer = 10 dekameters = 328.08 feet
 1 kilometer = 10 hectometers = 3,280.8 feet

Weights

1 centigram = 10 milligrams = .15 grain
 1 decigram = 10 centigrams = 1.54 grains
 1 gram = 10 decigrams = .035 ounce
 1 dekagram = 10 grams = .35 ounce
 1 hectogram = 10 dekagrams = 3.52 ounces
 1 kilogram = 10 hectograms = 2.2 pounds
 1 quintal = 100 kilograms = 220.46 pounds
 1 metric ton = 10 quintals = 1.1 short tons

Liquid Measure

1 centiliter = 10 milliliters = .34 fl. ounce
 1 deciliter = 10 centiliters = 3.38 fl. ounces
 1 liter = 10 deciliters = 33.81 fl. ounces
 1 dekaliter = 10 liters = 2.64 gallons
 1 hectoliter = 10 dekaliters = 26.42 gallons
 1 kiloliter = 10 hectoliters = 264.18 gallons

Square Measure

1 sq. centimeter = 100 sq. millimeters = .155 sq. inch
 1 sq. decimeter = 100 sq. centimeters = 15.5 sq. inches
 1 sq. meter (centare) = 100 sq. decimeters = 10.76 sq. feet
 1 sq. dekameter (are) = 100 sq. meters = 1,076.4 sq. feet
 1 sq. hectometer (hectare) = 100 sq. dekameters = 2.47 acres
 1 sq. kilometer = 100 sq. hectometers = .386 sq. mile

Cubic Measure

1 cu. centimeter = 1000 cu. millimeters = .06 cu. inch
 1 cu. decimeter = 1000 cu. centimeters = 61.02 cu. inches
 1 cu. meter = 1000 cu. decimeters = 35.31 cu. feet

Approximate Conversion Factors

To change	To	Multiply by	To change	To	Multiply by
inches	centimeters	2.540	ounce-inches	newton-meters	.007062
feet	meters	.305	centimeters	inches	.394
yards	meters	.914	meters	feet	3.280
miles	kilometers	1.609	meters	yards	1.094
square inches	square centimeters	6.451	kilometers	miles	.621
square feet	square meters	.093	square centimeters	square inches	.155
square yards	square meters	.836	square meters	square feet	10.764
square miles	square kilometers	2.590	square meters	square yards	1.196
acres	square hectometers	.405	square kilometers	square miles	.386
cubic feet	cubic meters	.028	square hectometers	acres	2.471
cubic yards	cubic meters	.765	cubic meters	cubic feet	35.315
fluid ounces	milliliters	29.573	cubic meters	cubic yards	1.308
pints	liters	.473	milliliters	fluid ounces	.034
quarts	liters	.946	liters	pints	2.113
gallons	liters	3.785	liters	quarts	1.057
ounces	grams	28.349	liters	gallons	.264
pounds	kilograms	.454	grams	ounces	.035
short tons	metric tons	.907	kilograms	pounds	2.205
pound-feet	newton-meters	1.356	metric tons	short tons	1.102
pound-inches	newton-meters	.11296			

Temperature (Exact)

°F	Fahrenheit temperature	5/9 (after subtracting 32)	Celsius temperature	°C
----	------------------------	----------------------------	---------------------	----

